



# **Parking Standards for New Developments**

Supplementary Planning Document

**A great place to live and work.**

## Revision History

Version	Description	Date	Initials
1	Final draft	September 2022	AS

## Contents

Guidance Documents .....	6
1.0 Introduction .....	7
2.0 Background .....	8

### **Parking standards for residential developments**

3.0 Cycle parking in residential developments .....	10
3.1 Visitor cycle parking at houses.....	10
3.2 Visitor cycle parking at flats and apartments .....	11
3.3 Residents cycle parking at houses .....	11
3.4 Residents cycle parking for flats and apartments.....	12
3.5 Cycle parking for non-standard cycles .....	13
3.6 Examples of well-integrated cycle parking at residential developments.....	14
3.7 Examples of poor cycle parking provision at residential developments .....	17
4.0 Car and van ownership in Central Bedfordshire .....	18
4.1 What factors influence the choice to own a car? .....	18
4.2 The role of parking standards in placemaking.....	19
4.3 Residential parking provision.....	19
4.4 Residential parking layout considerations.....	22
4.5 Car parking standards for residential developments .....	24
4.6 Car parking standards for residential developments in town centre locations, close to railway stations and the guided busway .....	26
4.7 Houses in multiple occupation (HMOs) .....	27
4.8 Accommodation for older people.....	28
4.9 Car-free developments .....	29
4.10 Disabled parking in residential developments.....	30
5.0 Parking for powered two-wheelers in residential developments .....	31

### **Parking Standards for Non-Residential Developments**

6.0 Cycle parking at non-residential developments .....	33
6.1 Short stay cycle parking .....	33
6.2 Long stay cycle parking .....	33
6.3 Cycle parking for non-standard cycles .....	34
6.4 Cycle parking at nurseries, pre-schools, and childcare for children up to age 4.....	34
6.5 Cycle parking provision at schools, sixth forms, colleges, higher and further education .....	34
6.9 Well-designed cycle parking at non-residential developments .....	36

6.10 Cycle parking in non-residential locations that don't meet user needs.....	38
6.11 Cycle parking standards for non-residential developments.....	40
7.0 Operational parking standards .....	46
8.0 Disabled parking at non-residential developments.....	53
9.0 Parking for powered two-wheelers at non-residential developments .....	54
Glossary of Terms.....	55

## **Appendices**

Appendix 1: Vehicle dimensions .....	58
Appendix 2: Cycle parking.....	59
Appendix 3: Cycle parking layouts .....	60
Appendix 4: Locations where developments within 500 metres of Arlesey railway station can use the relaxed parking standards .....	61
Appendix 5: Locations where developments within 500 metres of Biggleswade town centre can use the relaxed parking standards.....	62
Appendix 6: Locations where developments within 500 metres of Biggleswade railway station can use the relaxed parking standards.....	63
Appendix 7: Locations where developments within 500 metres of Dunstable town centre can use the relaxed parking standards .....	64
Appendix 8: Locations where developments within 500 metres of the Luton and Dunstable guided bus way stop adjacent to Portland Ride can use the relaxed parking standards.....	65
Appendix 9: Locations where developments within 500 metres of the Luton and Dunstable guided bus way stop adjacent to College Drive can use the relaxed parking standards .....	66
Appendix 10: Locations where developments within 500 metres of the Luton and Dunstable guided bus way stop adjacent to Dukeminster Close can use the relaxed parking standards .....	67
Appendix 11: Locations where developments within 500 metres of the Luton and Dunstable guided bus way stop adjacent to Jeans Way can use the relaxed parking standards.....	68
Appendix 12: Locations where developments within 500 metres of Flitwick town centre and railway station can use the relaxed parking standards .....	69
Appendix 13: Locations where developments within 500 metres of Leighton Buzzard town centre can use the relaxed parking standards .....	70
Appendix 14: Locations where developments within 500 metres of Leighton Buzzard town centre can use the relaxed parking standards .....	71
Appendix 15: Locations where developments within 500 metres of Sandy railway station can use the relaxed parking standards .....	72
Appendix 16: Residential parking layouts – driveway for a single vehicle .....	73
Appendix 17: Residential parking layouts – one parking space to the front of a property.....	74
Appendix 18: Residential parking layouts – driveway for two vehicles adjacent to one another ....	75

Appendix 19: Residential parking layouts – two parking spaces to the front of a property.....	76
Appendix 20: Residential parking layouts – driveway for two vehicles in a tandem arrangement..	77
Appendix 21: Residential parking layouts – driveway for two vehicles in a tandem arrangement, with two driveways adjacent to one another.....	78
Appendix 22: Residential parking layouts – driveway for three vehicles.....	79
Appendix 23: Residential parking layouts – driveway for three vehicles.....	80
Appendix 24: Residential parking layouts – driveway for four vehicles.....	81
Appendix 25: Residential parking layouts – driveway for four vehicles.....	82
Appendix 26: Residential parking layouts – communal perpendicular parking with footway.....	83
Appendix 27: Residential parking layouts – communal perpendicular parking with pedestrian walkway.....	84
Appendix 28: Residential parking layouts – disabled parking .....	85
Appendix 29: Residential parking layouts – on-street parallel lay-by parking .....	86
Appendix 30: Non-residential parking layouts: Perpendicular parking.....	87
Appendix 31: Non-residential parking layouts: perpendicular parking incorporating disabled parking, cycle parking and powered two-wheeler parking .....	88
Appendix 32: Disabled parking at off-street locations .....	89
Appendix 33: Disabled parking at on-street locations.....	90
Appendix 34: Car Club parking bays, parallel parking .....	91
Appendix 35: Car Club parking bays in a lay-by arrangement.....	92
Appendix 36: Powered two-wheeler parking .....	93

## Guidance Documents

### National Guidance

[BPA Parking Know How Bay Sizes \(2016\)](#)

[Traffic Signs Manual Chapter 3 \(2019\)](#)

[Traffic Signs Manual Chapter 5 \(2019\)](#)

[Traffic Signs Regulations and General Directions \(2016\)](#)

[The Highway Code](#)

[Guidance Note: Residential Parking \(CIHT, IHE\)](#)

[Guidelines for Motorcycling \(IHE\)](#)

[Inclusive Mobility \(DfT, 2021\)](#)

[Cycle Infrastructure Design \(LTN 1/20\)](#)

[Equality Act 2010](#)

[National Planning Policy Framework \(NPPF\)](#)

### Regional Guidance

[England's Economic Heartland Regional Transport Strategy](#)

### Local Guidance

[Local Plan](#)

[Design Guide](#)

[Highway Construction Standards & Specification Guidance](#)

[Highways Development Management Handbook](#)

[Central Bedfordshire Sustainability Plan](#)

On-Street Parking Management Strategy

[Electric Vehicle Charge Point Plan](#)

Sustainable Modes of Travel to Schools and Colleges Strategy

[Bus Service Improvement Plan](#)

## 1.0 Introduction

Central Bedfordshire Council is committed to tackling climate change. The Council's [Sustainability Plan](#) was adopted in September 2020. The plan sets out the actions the Council will take to achieve carbon neutrality by 2030. The transport choices that individuals make will strongly influence the Council's ability to achieve this target; active travel and shared transport are promoted within the plan over private car use.

One of the ways in which we can make a positive difference is through effective parking provision for all vehicle types in new developments. We want to encourage more walking and cycling for shorter journeys, and for longer journeys encourage more sustainable options such as using public transport wherever possible. Ensuring that routes are attractive and useable for pedestrians and cyclists is key to achieving this. Providing sufficient parking for all types of vehicles will be necessary so that parked vehicles do not dominate the street scene or prevent access for pedestrians and cyclists.

This document sets out the parking standards for new developments in Central Bedfordshire, including parking for cars, powered 2 wheelers, cycles, disabled parking and operational parking provision.

### 1.1 Formulation of the standards

This supplementary planning document (SPD) replaces the standards in the following documents:

Document title	Standard that is replaced
LATP3: Car Parking Strategy	Appendices B, C and D
Design Guide: 1. Place making in Central Bedfordshire	1.14 Residential and Commercial Parking Standards (p29).
LATP3: Cycle Parking Annexes	Whole document

To inform these revised standards, the Council has considered the following:

- The existing parking situation in Central Bedfordshire.
- Car ownership levels in Central Bedfordshire.
- Levels of on-street parking in more recent developments that have been designed using the existing parking standards.
- Parking standards adopted by neighbouring local authorities, particularly those with similar characteristics to Central Bedfordshire.
- Demographics in Central Bedfordshire.
- Results from the Central Bedfordshire Householder Travel Survey.

### 1.2 Adherence to the standards

This supplementary planning document includes standards, guidance, and example parking layouts. Developments are expected to meet the standards set out in this SPD. The standards have been developed to consider the specific location and variations in parking demand this is likely to create. It is accepted that there will always be exceptions or developments that have specific

circumstances that may warrant a relaxation to the standards. It is recommended that a developer that is considering promoting a development that doesn't follow the standards set out in this SPD should discuss their proposal with the Highways Development Management Team at the earliest opportunity. Guidance is provided for some areas where a standard is not required. Any developments that decide to include areas that are covered by guidance are expected to follow it. Example parking layouts are included in the appendices. Whilst the example layouts don't cover every possible scenario, the general principles and dimensions must be followed and can be applied to different layouts

## 2.0 Background

Central Bedfordshire is predominantly a rural authority covering 716 square kilometres, characterised by large open areas of countryside with picturesque villages, hamlets and small to medium sized market towns. Within easy commuting distance to London, much of the area has either a suburban or rural feel with the largest conurbations including Leighton-Linslade, Dunstable, Biggleswade, Houghton Regis, Sandy, and Flitwick.

Approximately 294,200 people live in Central Bedfordshire (according to the [2021 Census data](#), published by the Office for National Statistics in June 2022). It is a high growth area situated close to London, with good transport links. The main drivers for population growth are increased life expectancy, a rising birth rate (exceeding mortality rate) and net increased migration due to planned development growth.

The Adopted Local Plan proposes delivery of 39,350 new homes. This includes 32,000 new homes to meet the housing need of Central Bedfordshire and 7,350 homes to meet unmet housing need arising from Luton. The Local Plan will deliver approximately 24,000 new jobs over the plan period (2015-2035). More houses and more employment will result in more roads and more journeys, so it is important to ensure that this growth is delivered as sustainably as possible.



# **Parking Standards for Residential Developments**

### 3.0 Cycle parking in residential developments

To facilitate an increase in journeys that are cycled, it is important that conveniently located, secure cycle parking is provided at every new residential development for both residents and visitors. All cycle parking should be accessible and easy to use, with no inconvenient detours, steep slopes, or narrow access ways. The facilities provided should be easy to use by all members of the community at all life stages, without the need to lift or drag the cycle.

Electric bikes or E-bikes are becoming increasingly popular. Although e-bikes are approximately the same dimensions as a standard cycle they tend to be heavier due to the battery. This makes it even more important to consider how an e-bike may need to be manoeuvred.

**Table 1: Cycle parking standards for residential developments**

Type of property	Number of visitor cycle parking spaces required*	Number of residents cycle parking spaces required*
Houses	1	1 per bedroom
Flats and apartments	1 per 20 flats or apartments, with a minimum of 2.	1 per bedroom
Houses in multiple occupation (HMO)	2 per HMO**	1 per bedroom**
Sheltered housing, assisted living complexes, housing aimed at older people	1 per 20 residential units, with a minimum of 2.	1 per 20 bedrooms

\*All spaces to be suitable to park an adult sized cycle.

\*\*Planning permission is not required for HMOs with up to 6 bedrooms, therefore the cycle parking standards for an HMO with up to 6 bedrooms should be seen as best practice guidance. For HMOs that require planning permission, the cycle parking standards must be adhered to and demonstrated at the planning stage. Planning permission may be refused if the property falls short of the cycle parking standards.

#### 3.1 Visitor cycle parking at houses

Visitor cycle parking is aimed at short-term visits, where a cycle will normally be parked for up to 2 hours. It will depend on the type of housing as to what would be the most appropriate type of cycle parking.

Houses that have a garage or are designed to have access to a garden that is fenced or has a boundary wall don't necessarily need to provide any specific visitor cycle parking, providing that access from the edge of the property curtilage to the garden or garage is wide enough for a cycle to fit through, and a gate can be secured into a garden. If this requires accessing past parked vehicles in a driveway, additional width needs to be provided. Access to the cycle parking location

from the public highway will need to be considered; it may be necessary to provide a dropped kerb if one is not provided for vehicular access.

For houses that don't have cycle access to a garden, a cycle bar or ring mounted on a wall could be supplied for visitor parking. The location where this is installed would need to be carefully considered, so that the ground is suitable (surfaced in some form, rather than grass or flower border) and once a cycle is locked there the cycle isn't blocking access to any car parking provision, or access to a door to the property.

Residential cycle parking is required for each property; additional provision for visitor parking could be provided in the same form at the same location.

See [appendices 16-25](#) for driveway layouts incorporating cycle parking or cycle access.

### 3.2 Visitor cycle parking at flats and apartments

- Visitor cycle parking needs to be located close to each entrance to the building(s).
- Sheffield stands are the preferred type of cycle parking.
- One Sheffield stand counts as two spaces if it can be used from both sides.
- Short stay cycle parking doesn't need to be covered.
- The location where cycle parking is proposed should have a level of natural surveillance - located outside of a window, and where there is likely to be pedestrian traffic walking past or entering and exiting the building. The proposed location should be well lit and not hidden by landscaping or planting.
- Cycle parking should not be located where the useable footway width is reduced to less than 2 metres, it causes localized congestion or creates a trip hazard.

See [appendix 2-3](#) for Sheffield cycle stand details and layout options.

### 3.3 Residents cycle parking at houses

- Cycle parking for residents should be provided in a secure, covered, and lockable enclosure, preferably within the footprint of the building.
- To promote ease of use and cycling as the modal choice the cycle parking should preferably be located at the front of the house. This could be incorporated into the front of the property, in a specially constructed cycle shed or an easily accessible garage. The former should be designed with careful consideration in terms of its setting and urban design.
- Bin storage will need to be considered, to ensure that the designated cycle parking is not taken up by bins or bins are not blocking access to the cycle parking area.
- When provided within the footprint of the dwelling or as freestanding storage, cycle parking should be accessed by means of a door which is a minimum of 1 metre wide, with the internal space being at least 1 metre wide by 2 metres in length per cycle.
- Domestic garden sheds are not permitted as they are not secure and are likely to be used to store garden equipment, outdoor toys and other items which makes it inconvenient to access a cycle.

- Where provided, garages can be a convenient and secure place to park cycles. Where a garage is built to dimensions that could be used to park a car in, the size of the garage must allow cycles to be removed easily without first driving out any car parked within it.
- Where possible, charging for e-bikes should be provided.
- If cycle parking is provided within a garage, access to and from the garage must be considered. If a cycle needs to be moved past parked vehicles on a driveway, an additional 1-metre-wide width should be provided.

See [appendices 16-25](#) for driveway layouts incorporating cycle parking or cycle access.

### 3.4 Residents cycle parking for flats and apartments

Residents cycle parking is aimed at residents own cycles, where a cycle will normally be parked longer term including overnight. Residents cycle parking should be conveniently located, so that cycling is the first choice for short trips. Cycle parking for residents must be covered and secure, although this shouldn't be at detriment to convenience and accessibility.

- The preferred solution is for the cycle parking to be within the building footprint with an individual cage for each dwelling or a cycle stand for each cycle.
- Cycle parking should be spread throughout the site and relate to either each block or floor depending on the size of the building.
- Cycle parking should be conveniently located so that it is closer than the nearest non-disabled car parking space.
- The cycle parking provision should be located on the ground floor, in a location that has step free access and no steep gradients.
- The type of cycle parking should allow each cycle to be 'double locked'; this means that the cycle can be secured with a padlock to a fixed object, but also be located within a secure area that has an additional lock, such as a key controlled entry system to a designated cycle parking area, an underground parking area or a lockable cycle shelter.
- Cages have the benefit of allowing secure storage for other cycle related items, and potentially other items that residents may not want to store inside, such as car cleaning equipment or gardening equipment.
- Secure compounds must not have unsecured apertures large enough for anyone to climb in or a cycle to be passed through.
- Communal cycle parking areas should be well lit and be included in any premises' CCTV surveillance system.
- Where cycle parking is communal, this should be for a maximum of 50 cycles.
- Cycle parking provided outside of the building should be within a lit, covered enclosure, with cages or a freestanding lockable cycle shelter.
- Two tier cycle racks are discouraged, as cycles are less accessible and top tier cycle racks can be hard to use.
- Maintenance and management of communal cycle parking facilities will be the responsibility of the owners or the tenant of the dwelling. A funded maintenance regime should be put in place.
- The type of cycle parking should be low maintenance, self-explanatory and easy to use.

- Advice on the use of cycle parking should be provided in welcome packs where these are required as part of the development's travel plan. This should include not only the day-to-day up-keep but also the issuing of keys or other entry devices together with the introduction of the facilities and their use to new residents.
- Where possible, charging for e-bikes should be provided.

### **3.5 Cycle parking for non-standard cycles**

For both visitor and residents cycle parking, consideration must be given to providing spaces accessible to less conventional cycle types, such as recumbents, tricycles, hand cycles, cargo cycles, e-bikes, and cycles with trailers.

### 3.6 Examples of well-integrated cycle parking at residential developments

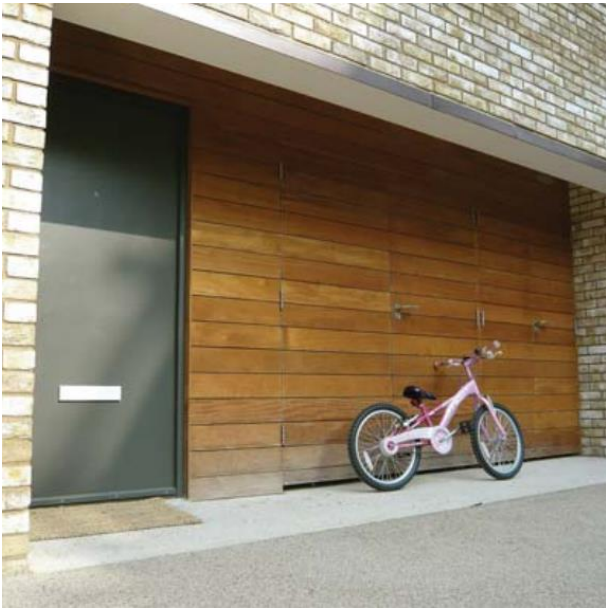

Cycle parking incorporated into the front of a property, whilst the materials used are in-keeping with the building style.



Cycle storage located to the front of a property.



Secure parking for cycles and a car through the implementation of two gates.



Wide garage doors allow access for a car and cycle independently of one another.





A cycle locker located at the front of a property, with space to store 2 adult cycles.

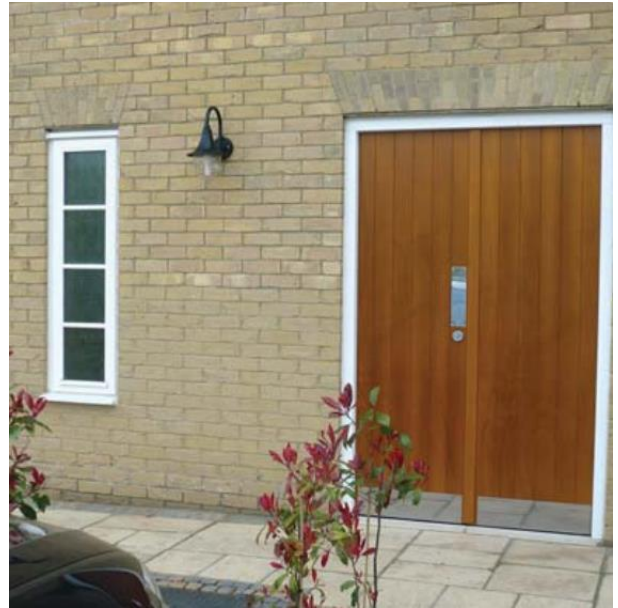

Entrance to a communal cycle parking area incorporated into the building.



A storage cage within a communal area assigned to an individual dwelling.



A secure cycle parking compound at a block of flats.



A lockable cycle shelter which would be suitable to use as shared residential cycle parking for flats, apartments and HMOs.

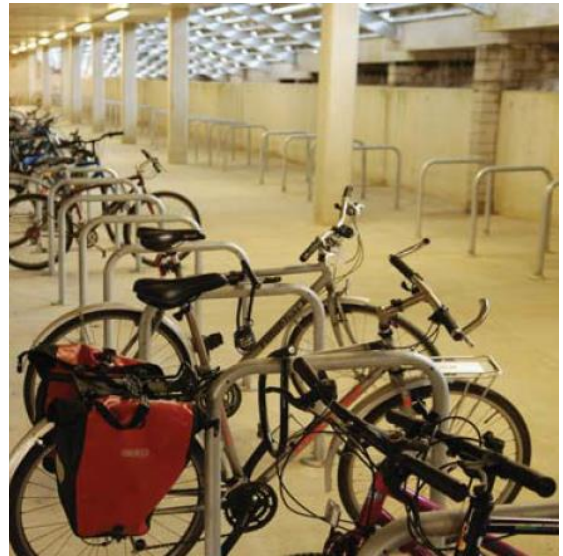

Sheffield stands provided in a secure under ground parking area.



A wall bar suitable for short-term visitor parking.



A wall anchor suitable for short-term visitor parking.



### 3.7 Examples of poor cycle parking provision at residential developments



Cycle parking provision at a commercial building that has been converted into residential apartments. The cycle parking is not covered, does not provide a fixed bar for the frame of the bike to be locked to and is not overlooked by any of the properties in the building.



Cycle parking racks for long-term parking at residential flats. Whilst the area is covered, there is no natural surveillance of the area, and no way for residents to double lock their bikes, leaving them vulnerable to theft. The style of stand requires a certain amount of upper body strength, therefore making this style not suitable for all to use.



Cycle parking racks for long-term parking at residential flats combined in a brick-built bin store. Bins and cycles should be accommodated in separate locations. Some of the cycle racks are not accessible due to the bins and rubbish has been dumped in between the cycle racks.



The long-term cycle parking at residential flats provided in the form of shelters with wheel slots. The provision does not allow for a bike frame to be locked to anything, and the proximity of a public footpath behind the site leaves cycles left there vulnerable to theft.

## 4.0 Car and van ownership in Central Bedfordshire

There were 157,000 cars or vans in Central Bedfordshire at the time of the 2011 Census. 46.7% of households owned two or more vehicles (compared to 32.1% nationally). The Householder Travel Survey carried out in June 2022 shows that car ownership has increased slightly since the Census was completed in 2011.

**Table 2: Cars and vans per household**

	Total (Central Bedfordshire) (2011 Census)	% Central Bedfordshire (2011 Census)	Householder Travel Survey (June 2022)	% England (2011 Census)
No car or van	13,800	13.2%	8%	25.8%
1 car or van	41,800	40.1%	42%	42.2%
2 cars or vans	36,200	34.7%	36%	24.7%
3 cars or vans	9,000	8.7%	14%	5.5%
4 or more cars or vans	3,500	3.3%		1.9%

### 4.1 What factors influence the choice to own a car?

Central Bedfordshire households have a higher-than-average number of cars or vans per household, particularly the number of households that have 2 or more vehicles. There are several possible reasons why this is the case.

#### 4.1.1 Location of work

The Householder Travel Survey completed in June 2022 showed that 49% of working residents commuted outside of Central Bedfordshire for work, with 30% travelling more than 20 miles to get to work. There are many employment areas within Central Bedfordshire and within the neighbouring authority areas; this makes it difficult to provide public transport to meet residents needs for commuting trips when there are multiple destinations and origins. In the [2011 census](#), 3% of residents specified their method of travel to work as travelling by bus, mini-bus, or coach, with 2% travelling by train. In comparison 62% travelled by car, and 6% travelled as a passenger in a car or van.

#### 4.1.2 Demographics

In Central Bedfordshire there is a higher number of residents that are economically active than the national average (74.7% in Central Bedfordshire, 69.9% nationally). It is likely that as household income rises so does car ownership. Car ownership is likely to be higher in households with more than one adult than in single adult households. 50.9% of households in Central Bedfordshire comprise of a couple with or without children, compared to 43% nationally. The presence of children in a household also increases the likelihood of having a car. 29.6% of households in Central Bedfordshire include dependent children, compared to 26.4% nationally.

The information above helps to demonstrate that there isn't one reason why car ownership is higher in Central Bedfordshire than the national average, there are multiple reasons. Whilst sustainability is high on the Council's agenda and encouraging sustainable modes of travel is part of our target to reach carbon neutrality by 2030, reducing the number of parking spaces for new residential developments is unlikely to see a reduction in car ownership.

## **4.2 The role of parking standards in placemaking**

In January 2011, the Coalition Government announced its intention "to end the war on motorists". One of the three elements of this announcement was the removal of national limits on residential parking spaces. Local authorities are required to set parking standards for their areas, but they should do so having regard for local circumstances and without trying to control car ownership. The need to promote sustainable transport outcomes is not affected. The Government has concluded that national constraint policies have led to "significant levels of on-street parking causing congestion and danger to pedestrians". In preparing new policies, local authorities are being urged "to make the right decisions for the benefit of their communities".

National planning policy is provided by the National Planning Policy Framework (NPPF) (2021). Paragraph 107 of the NPPF sets out the Government's approach to car parking standards stating that in setting local standards, local planning authorities should consider the accessibility of the development, the type, mix and use of the development, the availability of and opportunities for public transport, local car ownership levels, and the need to ensure an adequate provision of spaces for charging plug-in and other ultra-low emission vehicles.

## **4.3 Residential parking provision**

Accessibility and convenience of parking spaces in relation to the property has an impact on when parking spaces are used as intended and when on-street parking is favoured. Examples of existing developments in relation to on-street parking suggest that people want to be able to park as close to their property as possible. Parking that is further away or not overlooked is less likely to be used, particularly if unrestricted on-street parking is available closer to the property's front door than a provided off-street parking space.

### **4.3.1 Parking provision that isn't well used**

- Garages are often repurposed as utility rooms, storage or converted to be used as a room, particularly if attached to the property and served by utilities.
- Rear parking courts (especially where on-street parking is unrestricted, and closer than the off-street parking provision)
- Parking remote from the property – this could include allocated parking spaces that are located further away from the property's front door than unrestricted on-street parking.
- Parking spaces that are difficult to access – this may include where a space requires the user to reverse in or out for a distance, where turning space is restricted, or the space is constrained by a high boundary wall, planting area or other obstruction.
- Car ports and under croft parking – these can be used to store other items such as bins, which limits space to park a vehicle. The posts can sometimes reduce access, and homeowners may decide to install doors which then creates similar issues to garages.



### 4.3.2 Examples of parking provision that isn't used as designed



Vehicles parked opposite garages instead of inside them. Not enough space remains for a vehicle to get in or out of the garages.



Leaving half a car length in front of a garage results in vehicles parking and over-hanging the footway, particularly when one garage is the only form of parking provided.



Area allocated as footway space is used for parking. The property's allocated parking is at the side of the house, which is further from the front door. The design doesn't make it clear if this area is intended to be used as parking or footway.



A rear parking court accessed from the corner of a cul-de-sac is under-utilized, with residents preferring to park on-street closer to their front door.





A rear parking court that is remote from properties and under-utilized.



A driveway with boundary wall / fence both sides. Note how it would be difficult to use the side door to the house if another car was parked in the second parking space.



Properties designed with limited frontages and no rear access result in wheelie bins stored in driveways, and vehicles parked on-street.

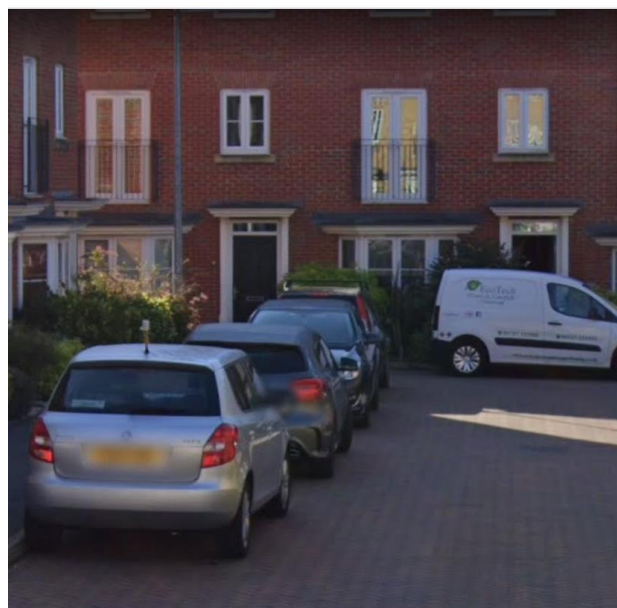

A mews style cul-de-sac is dominated by parked vehicles, as allocated parking is remote from properties.

## 4.4 Residential parking layout considerations

Those designing the layout of new developments should think about the convenience of the parking provision in relation to the property's front door. If parking on-street is available closer to the property's front door than any allocated provision, the allocated parking is unlikely to be used.

- Parking provision should have a natural level of surveillance from the property it is intended to serve.
- Landscaping should be given consideration as in some circumstances this can reduce the available parking bay size, obscure visibility, and manoeuvrability into / out of parking spaces.
- Walking routes for passenger access must be considered, including wheelchair access. Soft landscaping adjacent to a parking space is not permitted.
- Sufficient space needs to be provided to enable the intended vehicle to access and egress a proposed parking space.
- Swept path analysis may be requested for any parking bays that appear to be tight for the intended vehicle to get in or out of.

### 4.4.1 Garages

- Single garages will **not** count as a parking space.
- A double garage will count as **one** parking space.

The June 2022 Householder Travel Survey results show that only 14% of residents in Central Bedfordshire use their garage to park a car. 61% of residents that have a garage use it for another purpose, such as storage, a utility room, hobby room or gym. This results in on-street parking that often isn't factored into the road layout design. A developer can still provide a single garage or storage area which could be aimed at cycle storage, powered two-wheeler storage or other general storage. Where a single garage is provided, the dimensions of the garage don't need to allow for a car to fit into it and could be reduced in size compared to a standard sized garage.

### 4.4.2 Rear parking courts

Rear parking courts which are further away from the property than on-street parking and aren't overlooked by the vehicle owners are rarely used as intended and are discouraged.

### 4.4.3 Access for bins

Those designing the layout of new residential developments should consider where wheelie bins can be stored within the property curtilage and how wheelie bins can be put out and brought in on collection days. Parking spaces and access should be designed so that parked cars don't need to be moved to put bins out. Depending on the layout it may be necessary to provide additional width for driveways to allow wheelie bins to be moved past parked vehicles.

### 4.4.4 Access for cycles

Cycle parking is a requirement within all new developments. Those designing the layout of properties should consider the convenience of the cycle parking provision and how cycles can get from the designated cycle parking to the edge of the property curtilage. To promote cycling, cycle

parking should be easily accessible and where possible located at the front of a property. Parking spaces should be designed so that parked cars don't need to be moved to get a cycle in or out of the designated cycle parking. It may be necessary to provide additional width for driveways to allow bikes to be moved past parked vehicles.

#### **4.4.5 Communal parking areas**

It is recommended that where communal parking is proposed for flatted developments, a minimum of one parking space is allocated to each property. This could be through numbering the bays and displayed through signage or road markings. This is so that potential occupiers can make an informed decision about whether the parking provided will meet their requirements and reduce the possibility of neighbourhood disputes.

See [appendices 26 and 27](#) for communal parking layouts in residential settings.

#### **4.4.6 Electric vehicle charging point provision**

Developers will need to provide electric vehicle charging points to parking bays as per the Electric Vehicle Charging Technical Guidance. Developers will need to consider how EV charging points are powered, ensure enough space is provided around the parking bay to plug in an electric vehicle, whilst minimizing the need for trailing cables. Developers will be required to provide an Electric Vehicle Management Plan for all charge points that are not located within a property curtilage.

See [appendices 16-25](#) for driveway layouts incorporating electric vehicle charging.

#### **4.4.7 Parking Bay layouts and dimensions**

In the [appendices](#) are suggested layouts and dimensions for parking bays in different situations. Other parking layouts will be accepted but must follow these principles:

- The dimensions specified are a minimum standard, parking bays designed to smaller dimensions will not be accepted.
- Access and egress to every proposed parking space must be demonstrated upon request.
- Parking bays adjacent to solid structures must be widened by 1 metre to allow for improved manoeuvrability and entry / exit of people to / from the vehicle. If there is a solid structure on both sides of the parking bay, an additional 1 metre will be required both sides of the parking bay.
- Space to enable access around each parking bay must be included. Depending on the layout of the property and location of the parking, this will include access for pedestrians and wheelchair users, and may include a person pushing a cycle and a person pulling a wheelie bin.
- Soft landscaping adjacent to parking spaces is not permitted.

## 4.5 Car parking standards for residential developments

The following table shows the minimum number of car parking spaces required for residential developments in Central Bedfordshire. The standards reflect the level of car ownership in Central Bedfordshire.

**Table 3: Car parking standards for residential developments**

Number of bedrooms	Number of parking spaces required	Number of visitor parking spaces required
1 bedroom	1	0.25*
2 bedrooms	2	0.25*
3 bedrooms	2	0.25*
4 bedrooms	3**	0.25*
5 or more bedrooms	4**	0.25*

### 4.5.1 Visitor parking\*

- Visitor parking spaces should be provided on-street in the form of either a lay-by or widened section of carriageway.
- Any visitor spaces required will form part of the highway. The spaces should remain unallocated and available for anyone to use.
- Visitor spaces should preferably allow for a minimum of 2 spaces to be located adjacent to one another; this is so that larger vehicles such as delivery vehicles and those that need more space such as disabled people are able to use them.
- Visitor spaces should be evenly distributed throughout the proposed development, and not located all together. An exception to this is where the parking provision for the proposed development comprises of a communal parking area, for example where flats or apartments are proposed.

See [appendix 29](#) for residential parking layouts – on-street parallel lay-by parking.

### 4.5.2 3<sup>rd</sup> and 4<sup>th</sup> parking spaces\*\*

Where a property requires 3 or 4 parking spaces, the first 2 parking spaces must be provided. The third and / or fourth parking space(s) may be provided as accessible land that could be converted to parking by the homeowner. This could be provided as grass or a planted area. This must be clearly shown on drawings and meet the dimensions for parking bays and space required surrounding a parking bay. Any dropped kerb required should be installed so that the homeowner won't need to make any alterations if they chose to surface a third or fourth parking space. This standard can only be used where all the parking provision is within the property curtilage. This standard can only be used for properties that are freehold, where the dwelling is to be sold to a



private individual. It is not intended for social housing or houses that are proposed to be managed by a housing association.

See [appendices 16 to 29](#) for various residential parking layouts.

See also:

- [Car parking standards for residential developments in town centre locations and close to railway stations](#)
- [Car-free developments](#)
- [Houses in multiple occupation \(HMOs\)](#)
- [Accommodation for older people](#)
- [Cycle parking standards for residential developments](#)

## 4.6 Car parking standards for residential developments in town centre locations, close to railway stations and the guided busway

The following table shows the minimum number of car parking spaces for residential developments proposed for town centre locations, those that are near to the main railway stations in Central Bedfordshire and the guided busway in Dunstable and Houghton Regis. This standard is intended to be used for infill developments of up to 15 dwellings, but not houses of multiple occupation. A town centre location is defined as being located within 500 metres of a town centre, railway station or bus stop along the guided busway in one of the following towns: Arlesey, Biggleswade, Dunstable, Flitwick, Leighton-Linslade and Sandy.

See [appendices 4 to 15](#) for plans showing the area and list of streets this covers.

**Table 4: Car parking standards for infill residential developments (up to 15 dwellings) in town centre locations, close to railway stations and the guided busway**

Number of bedrooms	Number of parking spaces required	Number of visitor parking spaces required
1 bedroom	1	0
2 bedrooms	1	0
3 bedrooms	2	0
4 bedrooms	2	0
5 bedrooms or more	3	0

- Visitor parking spaces are not required as public car parks are available within walking distance.
- Developments within existing resident parking zone areas will **not** be entitled to purchase any permits to park on the surrounding streets.
- A developer may be asked to pay or contribute towards the cost of implementing measures to manage on-street parking on nearby streets to the proposed development. Any proposed measures would be subject to a statutory consultation. This is to discourage occupiers owning additional vehicles to the allocated parking spaces and parking them on-street at the detriment to other residents.
- A developer may be asked to pay or contribute towards the cost of upgrading the pedestrian route to the nearest railway station or bus stop.

See also:

- [Car parking standards for residential developments](#)
- [Car-free developments](#)
- [Houses in multiple occupation \(HMOs\)](#)
- [Accommodation for older people](#)
- [Cycle parking standards for residential developments](#)

## 4.7 Houses in multiple occupation (HMOs)

The following table shows the minimum number of car parking spaces for houses in multiple occupation.

**Table 5: Car parking standards for houses in multiple occupation (HMOs)**

Number of bedrooms	Number of parking spaces required	Number of visitor parking spaces required
3 bedrooms	3*	0
4 bedrooms	4*	0
5 bedrooms	5*	0
6 bedrooms	6*	0
7 bedrooms	7	0
8 bedrooms or more	8, plus one per additional bedroom	0

- \*Planning permission is not usually required for HMOs with up to 6 bedrooms, therefore the parking standards for an HMO with up to 6 bedrooms should be seen as guidance.
- Where an HMO is proposed with up to 6 bedrooms but without any parking, good quality cycle parking provision is recommended.
- For HMOs that don't require planning permission and an HMO is located within a Residents Parking Zone area, the property will be counted as one property, with permits issued on a first come, first served basis. This is because RPZs are usually implemented in locations where there is a high demand for on-street parking. The conversion of a family home to an HMO can significantly add to parking pressures in the surrounding streets.
- For HMOs that require planning permission, the parking standards must be adhered to and demonstrated at the planning stage. Planning permission may be refused if the property falls short of the parking standards, and it is considered that the likely additional vehicles would have a detrimental impact on parking in the surrounding streets.

See also:

- [Car-free developments](#)
- [Accommodation for older people](#)
- [Cycle parking standards for residential developments](#)

## 4.8 Accommodation for older people

The following table shows the minimum number of parking spaces for accommodation aimed at older people. This could include sheltered housing, assisted living complexes and any other housing aimed specifically for older people.

**Table 6: Parking standards for accommodation for older people**

Number of residents parking spaces required*	Number of visitor parking spaces required	Number of staff parking spaces required	Number of spaces for mobility scooters
1 space per dwelling*	1 space per 4 dwellings	1 per 2 staff	1 space per 2 dwellings**

\* The number of parking spaces provided for residents can be reduced when a Car Club scheme is promoted and operated as part of the development. Where a Car Club is proposed, a Car Club Management Plan will be required which sets out how the scheme will operate and who is responsible for maintaining the vehicles.

\*\*Mobility scooter parking spaces should be secure, covered and include electric charging facilities.

- Where a Car Club is promoted, vehicles should ideally be electric vehicles, therefore electric vehicle charging points must be provided for each Car Club vehicle, including designated Car Club parking spaces.
- A mobility scooter hire scheme could be included as part of the development.
- Where accommodation is specifically designed for older or disabled people parking bays that are designed to the dimensions of a disabled parking bay may be of benefit to the residents and may be requested.

See [appendices 34 and 35](#) for Car Club Parking Bay layouts

See [appendix 28](#) for Residential parking layouts – disabled parking

See also:

- [Cycle parking standards for residential developments](#)
- [Parking standards for nursing and care homes](#)

## 4.9 Car-free developments

Whilst encouraging residents to use modes of travel other than private cars is a priority, alternative transport provision needs to be in place to enable that change to happen. This includes public transport (especially for journeys commuting to and from work) and walking and cycling routes for shorter journeys. It isn't feasible to remove parking spaces and expect residents to give up their cars without there being alternative modes of travel available. Doing so is likely to result in high levels of on-street parking which is detrimental to encouraging walking and cycling.

There is a growing consumer demand for more sustainable development, and there are certain situations where car free development may be permitted, for example:

- Conversion of an existing building for residential use where parking standards cannot be met.
- Subdivision of an existing residential property into multiple properties where parking standards cannot be met.

Car-free developments will only be considered when:

- A parking survey is submitted that demonstrates it is either: possible to allow additional on-street parking; or there is no feasible place to park on-street due to existing restrictions within a 200-metre radius of the proposed development. This is to ensure that any additional parking generated will not have a detrimental impact on parking levels in the surrounding streets, and car ownership is discouraged.
- The site is in an accessible location within a mile of a local shop or supermarket, a pre-school or nursery, a lower or primary school, green space, and a children's play area. This is to ensure that the most frequently made local journeys can be walked or cycled.
- Existing public transport and walking and cycling connections to the development should be identified in the application and demonstrate a level of service(s) that negate the need to own a car.
- Good quality cycle parking provision is prioritised.

Car-free development is unlikely to be suitable for accommodation aimed at certain groups of people, such as disabled people and the elderly as they may be restricted in the distance that they are able to walk. These groups often rely on a car to maintain their independence, or if not able to drive use other services such as taxis, dial-a-ride services or family and friends that will need to be able to collect the resident from close to their property.

Residents of a car free development will not be eligible for a parking permit should a residents parking zone exist in the area or close by.

Each car-free development proposed will be assessed on its own merits. Developers considering promoting a car free development should contact the Highways Development Management Team at the earliest opportunity to discuss their proposal.

See also:

- [Houses in multiple occupation \(HMOs\)](#)
- [Cycle parking standards for residential developments](#)

#### 4.10 Disabled parking in residential developments

For residential developments disabled parking spaces allocated solely for the use of a disabled person won't usually be required. This is because it is impossible to know which properties may have a disabled resident. The parking bay layouts and dimensions particularly for driveway parking have considered the needs of disabled people, with additional space specified for each side of a parking bay to enable a disabled person to access a parked vehicle. This is to ensure that new residential properties are suitable for a disabled person to occupy whilst also ensuring compliance with the [Equality Act 2010](#). The Equality Act states that reasonable adjustments must be made where facilities provided put a disabled person at a substantial disadvantage in comparison with persons who are not disabled.

Where a communal parking area is proposed for flats and apartments, the parking bay dimensions specified for a disabled persons parking space will be required for one space per dwelling for all ground floor flats and apartments. This is so that the flat or apartment could be adapted for use by a disabled person. In this case the parking spaces should be located as close to the entrance to the property as possible. The allocation of the parking bay to the property should be made clear through numbering of the parking bay. Where spaces are allocated to a particular property, road markings to depict a disabled parking bay and an upright disabled parking sign are not required. A flush surface should be provided between the parking bay and surrounding area, as a minimum a flush dropped kerb should be provided to allow wheelchair users to access an adjacent footway.

In communal parking areas, visitor parking spaces should be designed to disabled parking bay dimensions but marked as visitor spaces rather than disabled parking spaces. This will give greater flexibility in making visitor spaces suitable for disabled users. The allocation of disabled parking spaces in developments where there isn't necessarily a demand can either lead to the spaces being underutilized or used by those that don't have a disabled person's blue badge. This can lead to neighbourhood disputes.

Where accommodation is specifically designed for older or disabled people parking bays that are designed to the dimensions of a disabled parking bay may be of benefit to the end user and may be requested.

See [appendices 16-25](#) for various residential parking layouts.

See [appendix 28](#) for disabled parking layouts in residential settings.

## 5.0 Parking for powered two-wheelers in residential developments

According to the [Department for Transport's statistical dataset](#), at the end of 2020, there were 6,900 motorcycles registered in Central Bedfordshire (which makes up approximately 3.5% of the registered vehicles in Central Bedfordshire).

There is no requirement to provide dedicated parking for powered two-wheelers at residential developments. However, developers may choose to do so. If dedicated parking for powered two-wheelers is provided, the following design principles should be followed:

- Any dedicated powered two-wheeler parking provided should be covered.
- The parking should be secure.
- Access to and from the powered two-wheeler parking to the public highway should be considered, without the need for any parked vehicles to be moved.
- Parking areas must have a firm surface capable of supporting the weight of a motorcycle through its stand. A garden shed with a wooden floor is not suitable.
- The width of the motorcycle's handlebars (typically up to 1 metre wide) will need to be considered to ensure that any door provided to access a storage area is wide enough.

**Parking  
Standards for  
Non-  
Residential  
Developments**



## 6.0 Cycle parking at non-residential developments

To encourage the use of sustainable modes of travel, it is important that convenient, secure cycle parking is provided at every new non-residential development for long-term stays (for those working at the building) and short term for visitors and customers. All cycle parking should be accessible and easy to use, with no inconvenient detours, steep slopes, or narrow access ways. The facilities provided should be easy to use by all members of the community at all life stages, ideally without the need to lift or drag the cycle.

Different types of cycle should also be considered, such as recumbents, trikes, and hand cycles (which are often used by people with disabilities), cargo bikes and e-bikes. These all take up more space than a standard cycle, and this should be factored in when planning cycle parking layouts.

### 6.1 Short stay cycle parking

Short stay cycle parking is mostly for visitors or customers, where a cycle will normally be parked for up to 2 hours. Several things should be considered when designing the parking:

- It needs to be sited in the most convenient and accessible location, normally next to the entrance to the building.
- The location where cycle parking is proposed should have a level of natural surveillance, for example located outside of a window and where there is likely to be pedestrian traffic walking past or entering and exiting the building.
- The proposed parking should not reduce the footway width and cause localized congestion or create a trip hazard.
- The preferred type of cycle parking is the Sheffield stand. One Sheffield stand counts as two spaces if it can be used from both sides.
- It may be necessary to provide a dropped kerb where cycle parking is located on a footway.

### 6.2 Long stay cycle parking

Long stay cycle parking is normally for employees, who are likely to leave their cycles for the duration of the working day. Several things should be considered when designing the parking:

- It should be sited in a convenient location.
- Security and weather protection are also important. Long-stay cycle parking must be covered, so that cycles don't deteriorate if left exposed to the elements for long periods of time. This could be in the form of a purpose-built shelter, a bespoke shelter, incorporated into the building or under the overhang of a building.
- The preferred type of cycle parking is the Sheffield stand. One Sheffield stand counts as two spaces if it can be used from both sides.
- For larger developments where more than 50 cycle parking spaces are required two-tier cycle racks are also acceptable, however at least 20% of the overall long stay cycle parking provision should be Sheffield stands, to accommodate cycles that are not compatible with cycle racks. Racking systems are best provided where it is possible to provide instructions for use so that cyclists use the facilities safely.
- The security of cycles parked in the designated cycle parking area (and the user's perception of safety) are important to encourage modal shift. Long-term cycle parking must have an additional layer of security other than just relying on a cycle lock. This could

be in the form of a locked compound with controlled access, or a gated access system to the development. Where this cannot be achieved cycle lockers may be a better option.

- It is recommended that supporting facilities (such as lockers, showers and changing rooms) are provided at land uses where long stay cyclists require them, for example places of employment.

See [appendix 2 and 3](#) for cycle parking layouts.

### **6.3 Cycle parking for non-standard cycles**

For both long-stay and short-stay parking, consideration should be given to providing spaces accessible to less conventional cycle types, such as recumbents, tricycles, hand cycles, cargo cycles, e-bikes, and cycles with trailers. This could be facilitated by allowing extra space at the end of a row of Sheffield stands. 5% of cycle parking provision should be accessible for alternative types of cycle, particularly those used by disabled people.

### **6.4 Cycle parking at nurseries, pre-schools, and childcare for children up to age 4**

Younger children are likely to use a range of wheeled vehicles to get to and from their childcare. This could include sit and ride toys, scooters, cycles (some with stabilizers) and some may come in a pushchair. Standard cycle parking will not be suitable to accommodate all types of wheeled vehicles. It is recommended that a designated covered area is provided where such items can be stored. The types of vehicles that younger children use will not always be lockable, therefore the area should be secured by other means (it is usually the case that a building aimed at childcare will be secured by a perimeter fence with access control, therefore providing the designated storage area is within the curtilage, no other measures are required). Long-term cycle parking must also be provided for staff. This should be provided in accordance with section 6.2.

### **6.5 Cycle parking provision at schools, sixth forms, colleges, higher and further education**

Most of the cycle parking at schools will need to be long-term. Where space permits separate cycle parking should be provided for staff to that aimed at pupils. Where possible, a cyclable route from the school entrance to the cycle parking should be provided. If more than one entrance into the school is routinely used, cycle parking should be located close to each entrance. 5% of cycle parking at schools should be provided for non-standard cycles.

#### **6.5.1 Primary schools**

Primary aged pupils are likely to use a mix of cycles and scooters. A mix of Sheffield stands for cycles and scooter parking should be provided. Sheffield stands are available in a junior size which are a lower height aimed at children's cycles. Two-tier cycle racks are not suitable for primary schools as pupils are unlikely to be able to use them independently. Younger children will not always lock their cycles or scooters; therefore, the area should be secured by other means (it is usually the case that a building aimed at childcare will be secured by a perimeter fence with access control, therefore providing the designated storage area is within the curtilage, no other measures

are required). Cycle parking must also be provided for staff. This should be provided in accordance with section 6.2.

### **6.5.2 Secondary schools, sixth forms, colleges, higher and further education**

Secondary school aged pupils are more likely to cycle to school than scoot, although there still may be some pupils that prefer to scoot. Pupils who are aged 16+ are more likely to cycle than scoot. Cycle parking must be covered, so that cycles don't deteriorate if left exposed to the elements for long periods of time. This could be in the form of a purpose-built shelter, a bespoke shelter, incorporated into the building or under the overhang of a building. The preferred type of cycle parking is the Sheffield stand. One Sheffield stand counts as two spaces if it can be used from both sides. For larger schools and colleges where more than 50 cycle parking spaces are required and space is constrained, two-tier cycle racks are also acceptable. At least 20% of the overall cycle parking provision should be Sheffield stands, to accommodate cycles that are not compatible with cycle racks. Racking systems are best provided where it is possible to provide instructions for use so that cyclists use the facilities safely.

### **6.5.3 SEND schools**

A SEND school is for children or young people who have Special Educational Needs and Disabilities. This may include a learning difficulty and / or a disability that means they need special health and education support. The cycle parking provision for each SEND school should be based on the needs of the pupils; there may be some pupils that are able to cycle a standard cycle, therefore cycle parking should be provided. Other pupils won't be able to use a standard cycle but may be able to use an adapted cycle or trike. A designated covered area should be provided to allow for the storage of adapted cycles and trikes. This area could also be used to store wheelchairs, walkers, and other specialist equipment when not in use. It is noted that adapted cycles, trikes, and other specialist equipment is expensive and could be a target for theft, therefore the area must be secure. Cycle parking must also be provided for staff. This should be provided in accordance with section 6.2.

## 6.9 Well-designed cycle parking at non-residential developments



A secure cycle parking area at a secondary school. The area is fenced and covered with a lockable gate, and incorporates a combination of Sheffield stands and two tier cycle racks.



A cycle shelter which incorporates both cycle parking and scooter parking, suitable for a primary school.



A cycle shelter with Sheffield stands incorporated at a primary school. Note how none of the bikes appear to be locked and the volume of bikes compared to the number of spaces.



Lockable cycle hangars for long stay cycle parking and a shelter with Sheffield stands for short-stay cycle parking at an industrial unit.





Short-term cycle parking located outside a supermarket. The cycle parking is under a canopy, is closer to the main entrance than any car parking spaces and is located so as not to block access for pedestrians.



Short-term Sheffield stands located directly outside of a convenience store. Note the stands have been located close to the building so as not to obstruct the footway, but can only be used for one bike rather than on both sides.



Sheffield stands under a shelter at a leisure centre provide good short-term parking for visitors, located close to the main entrance.



Planter style cycle parking outside a historic church. Whilst it wasn't possible to provide any permanent cycle parking that was secured to the ground, these provide a short-term parking solution.



## 6.10 Cycle parking in non-residential locations that don't meet user needs



Cycle parking provision squeezed into the corner of a car park. If vehicles are parked in both spaces adjacent to the cycle parking area, access to the cycle parking (and bin storage behind) is restricted.



Short-term cycle parking at a local convenience store. The space is constrained, the cycle stands appear to be too low for an adult bike frame to be secured to and the only access to the cycle parking is via the dropped kerb next to the disabled parking bay.



Cycle parking at a commercial building. The cycle parking is not covered and there isn't a dropped kerb to enable cyclists to access the cycle parking. Without a gated entrance to the premises and no additional security, bikes could be vulnerable to theft.



Cycle parking at a retail park. There is no dropped kerb for cyclists to access the cycle parking, and its location in the top corner of the car park is not convenient when there are many parking spaces that are closer to each retail unit. There is no additional layer of security for long-term cycle parking.





Cycle parking at a commercial building. Whilst the provision of a shelter with Sheffield stands is ok, there is no additional layer of security. The location is not overlooked by the building it serves and the proximity to the road leaves bikes vulnerable to theft.



Short-term parking outside a supermarket, which partially blocks the pedestrian route in and out of the entrance and exit.



Cycle parking outside a leisure centre where Sheffield stands have been installed too close to the edge of the block paved area, meaning that bikes locked here would be partly on the grass.



Cycle parking aimed at short-stay visitors in a town centre are located too far away from any key destinations.

## 6.11 Cycle parking standards for non-residential developments

- Developers should supply the sum of both short and long stay cycle parking, remembering that the type of provision and the location may be different for each type.
- 1 Sheffield stand = 2 cycle parking spaces if the cycle stand can be used from both sides.
- Where ratios are for staff, this will normally either be calculated for the full-time equivalent or, where there is shift working such as in shops, factories, hotels and care homes, the maximum number of staff using the development at any one time.
- For locations where sufficient existing public cycle parking is available within a 50-metre radius (for example within a town centre) the standards may be relaxed. This will be at the discretion of the Highways Development Management Team. The developer may be required to contribute towards upgrading the existing facilities.
- If the developer is unable to provide cycle parking to the standards specified due to space constraints, they may be asked to contribute towards cycle parking that can be installed nearby on the public highway.
- When cycle parking is provided for general use, 5% of the cycle parking provision needs to be accessible for alternative types of cycle, particularly those aimed at disabled people.
- It is recommended that an applicant requests pre-application advice to gain clarification for a specific development, particularly where a proposed development has mixed uses, or if the development doesn't fit one of the categories listed. Where the use class in question is not specifically referenced, parking requirements will be determined on a case-by-case basis.



**Table 7: Cycle parking standards for non-residential developments**

Use class	Use	Number of short stay cycle parking spaces required	Number of long stay cycle parking spaces required
B2: General industrial		4 per customer entrance	1 per 10 staff in urban and edge of urban locations
			1 per 20 staff in rural locations
			Cycle parking for 2 pool bikes (to be determined on a site-by-site basis)
B8: Storage and distribution		4 per customer entrance	1 per 10 staff in urban and edge of urban locations
			1 per 20 staff in rural locations
			Cycle parking for 2 pool bikes (to be determined on a site-by-site basis)
C1: Hotels	Hotels, boarding and guest houses	4	1 per 10 staff in urban and edge of urban locations
			1 per 10 bedrooms in urban and edge of urban locations
			1 per 20 staff in rural locations
			1 per 20 bedrooms in rural locations
C2: Residential institutions	Nursing and care homes	4 per visitor entrance	1 per 10 staff in urban and edge of urban locations
			1 per 20 staff in rural locations

Use class	Use	Number of short stay cycle parking spaces required	Number of long stay cycle parking spaces required:
Class E: Commercial, business and service	E(a)(i) display or retail sale of goods, other than hot food, supermarkets, or food retail	less than 200m <sup>2</sup> : 1 per 100m <sup>2</sup> 200m <sup>2</sup> to 1,000m <sup>2</sup> : 1 per 200m <sup>2</sup> 1,000m <sup>2</sup> +: 1 per 500m <sup>2</sup>	less than 200m <sup>2</sup> : 1 per 100m <sup>2</sup> 200m <sup>2</sup> to 1,000m <sup>2</sup> : 1 per 200m <sup>2</sup> 1,000m <sup>2</sup> +: 1 per 500m <sup>2</sup>
	E(a)(ii) supermarket / food retail	1 per 250m <sup>2</sup>	1 per 500m <sup>2</sup>
	E(b) sale of food or drink for consumption (mostly) on the premises	4 per visitor entrance	1 per 10 staff
	E(c)(i): Financial services	4 per visitor entrance	1 per 10 staff
	E(c)(ii): Professional services	4 per visitor entrance	1 per 10 staff
	E(c)(iii): Other appropriate services in a commercial, business or service locality	4 per visitor entrance	1 per 10 staff
	E(d): Indoor sport, recreation, or fitness (not swimming pools)	1 per 10 visitors (at peak times)	1 per 10 staff
	E(e) Medical or health services	4 per visitor entrance	1 per 10 staff
	E(f) Creche, day nursery or day centre	4 per visitor entrance	1 per 10 staff in urban and edge of urban locations 1 per 20 staff in rural locations

Use class	Use	Number of short stay cycle parking spaces required	Number of long stay cycle parking spaces required
Class E: Commercial, business and service	E(g)i: Offices to carry out any operational or administrative functions	4 per visitor entrance	1 per 10 staff in urban and edge of urban locations, with a minimum of 2.
			1 per 20 staff in rural locations, with a minimum of 2.
			Cycle parking for 2 pool bikes (to be determined on a site-by-site basis).
	E(g)ii: Research and development of products or processes	4 per visitor entrance	1 per 10 staff in urban and edge of urban locations with a minimum of 2.
			1 per 20 staff in rural locations, with a minimum of 2.
			Cycle parking for 2 pool bikes (to be determined on a site-by-site basis).
	E(g)iii: Industrial processes	4 per visitor entrance	1 per 10 staff in urban and edge of urban locations with a minimum of 2.
			1 per 20 staff in rural locations, with a minimum of 2.
			Cycle parking for 2 pool bikes (to be determined on a site-by-site basis)

Use class	Use	Number of short stay cycle parking spaces required	Number of long stay cycle parking spaces required
F1(a) Provision of education * Where a school has a high percentage of pupils that qualify for school transport, this may be relaxed. This will be based on reviewing the Hands Up Data for the school.	Pre-schools (ages 2-4 years)	N/A	A covered area which is approximately 10 metres <sup>2</sup> for bikes with stabilisers, sit and ride toys etc.  Cycle parking: 1 per 10 staff
	Primary schools (reception, years 1 to 6)	N/A	A covered area which is approximately 2 metres <sup>2</sup> for bikes with stabilisers and adapted trikes.  Cycle parking: 1 per 20 pupils *  Scooter parking: 1 per 20 pupils *  Cycle parking: 1 per 10 staff
			Cycle parking: 1 per 10 pupils. *  Cycle parking: 1 per 10 staff
			Cycle parking: 1 per 10 pupils *  Cycle parking: 1 per 10 staff
	Secondary schools (years 7 to 11):	N/A	Cycle parking: 1 per 10 pupils *  Cycle parking: 1 per 10 staff
			Cycle parking: 1 per 10 pupils *  Cycle parking: 1 per 10 staff
	6 <sup>th</sup> form (years 12 and 13):	N/A	Cycle parking: 1 per 10 pupils *  Cycle parking: 1 per 10 staff
			Cycle parking: 1 per 10 students  Cycle parking: 1 per 10 staff
	Higher and further education:	N/A	Cycle parking: 1 per 10 students  Cycle parking: 1 per 10 staff
	SEND schools	N/A	Standards to be determined on a site-by-site basis.

Use class	Use	Number of short stay cycle parking spaces required	Number of long stay cycle parking spaces required
F1 Learning and non-residential institutions	F1(d) Libraries	4 per visitor entrance	1 per 10 staff, with a minimum of 2.
	F1(f) Public worship or religious instruction (or in connection with such use)	1 per 10 seats	1 per 10 staff, with a minimum of 2, where there are permanently located staff.
F2: Local community	F2(a) Retail (less than 200m <sup>2</sup> )	1 per 100m <sup>2</sup>	1 per 100m <sup>2</sup>
	F2(a) Retail (200m <sup>2</sup> to 1,000m <sup>2</sup> )	1 per 200m <sup>2</sup>	1 per 200m <sup>2</sup>
	F2(a) Retail (1,000m <sup>2</sup> +) )	1 per 500m <sup>2</sup>	1 per 500m <sup>2</sup>
	F2(b) Halls or meeting places for the principal use of the local community	1 per 50m <sup>2</sup> of public floor area	1 per 10 staff with a minimum of 2, where there are permanently located staff.
	F2(c) Areas or places for outdoor sport or recreation	1 per 10 players, or 5 per pitch, or 1 per tennis court	1 per 10 staff with a minimum of 2, where there are permanently located staff.
	F2(d) Indoor or outdoor swimming pools or skating rinks	1 per 10 visitors (at peak times)	1 per 10 staff with a minimum of 2.
Sui Generis (in a class of its own)	Fuel stations (with shop)	2	1 per 10 staff, with a minimum of 2.
	Hot food takeaways (including drive throughs)	4	1 per 10 staff, with a minimum of 2.
	Cinemas and concert halls	1 per 20 seats	1 per 10 staff, with a minimum of 2.
	Dance halls, bingo halls and casinos	1 per 20 seats	1 per 10 staff, with a minimum of 2.
	Live music venues and theatres	1 per 20 seats	1 per 10 staff with a minimum of 2.

## 7.0 Operational parking standards

The aim of adopting vehicle parking standards for new developments is to reduce the likelihood of vehicles associated with a proposed non-residential development parking on the public highway. The standards listed are the minimum number of parking spaces required dependent on the type and size of the proposed development.

Operational parking is defined as the space required for vehicles regularly and necessarily involved in the servicing of a business or buildings. It includes space for commercial vehicles delivering goods to or collecting goods from premises, space for loading and unloading and for picking up and setting down passengers. A commercial proposal should include adequate provision for servicing. The proposed layout should:

- Provide for all loading and other servicing to be safely carried out on site.
- Accommodate the number and size of delivery vehicles likely to be on site at any one time, to prevent delivery vehicles having to queue or reverse on the street.
- Allow (where possible) for refuse collection to take place within the development.
- Incorporate loading bays of a dimension which will cater for the largest size of service vehicle likely to be used.
- Allow service vehicles to manoeuvre with ease. There should be space within the site for a vehicle to either turn in a single manoeuvre or to complete a three-point turn. All service vehicles should be able to leave the service area in a forward gear. Swept path analysis will be required to demonstrate this.
- Not inconvenience other users of the site when service vehicles are being loaded or unloaded.
- The parking standards will be used as a starting point to determine the required number of parking spaces (including operational parking spaces) for any proposed development.
- All areas refer to the gross floor area (GFA) of the proposed development, measured in metres<sup>2</sup>.
- It is recommended that an applicant requests pre-application advice to gain clarification for a specific development, particularly where a proposed development has mixed uses, or if the development doesn't fit one of the categories listed.
- Where the use class in question is not specifically referenced, parking requirements will be determined on a case-by-case basis.

See [appendix 1](#) for vehicle dimensions.

### 7.1.1 Electric vehicle charging point provision

Developers will need to provide electric vehicle charging points to parking bays as per the Electric Vehicle Charging Technical Guidance. Developers will need to consider how EV charging points are powered, and ensure enough space is provided around the parking bay to plug in an electric vehicle whilst minimizing the need for trailing cables. Developers will be required to provide an Electric Vehicle Management Plan for any charge points that are proposed to be located on adoptable highway.

See [appendices 16 - 28](#) for various parking bay layouts with EV charge points integrated.



### **7.1.2 Parking Bay layouts and dimensions**

In the [appendices](#) are suggested layouts and dimensions for parking bays in different situations. Other parking layouts will be accepted but must follow these principles:

- The dimensions specified are a minimum standard, parking bays designed to smaller dimensions will not be accepted.
- Access and egress to every proposed parking space must be demonstrated upon request.
- Parking bays adjacent to solid structures should be widened by 1 metre (1 metre each side if solid structures are present both sides) to allow for improved manoeuvrability and entry / exit of people to / from the vehicle.

**Table 8: Minimum parking standards for non-residential developments (including operational parking standards)**

Use class	Use	Number of parking spaces	Operational parking requirement
B2: General industrial		1 per 30m <sup>2</sup> (for the first 500m <sup>2</sup> ), plus 1 per 100m <sup>2</sup> (for anything over 500m <sup>2</sup> )	1 space for an articulated vehicle (for the first 280m <sup>2</sup> ), plus 1 additional space per additional 500m <sup>2</sup> .
B8: Storage and distribution		1 per 30m <sup>2</sup> (for the first 500m <sup>2</sup> ), plus 1 per 200m <sup>2</sup> (for anything over 500m <sup>2</sup> )	2 spaces for articulated vehicles (for the first 280m <sup>2</sup> ), plus 1 additional space per additional 500m <sup>2</sup> .
C1: Hotels	Hotels, boarding and guest houses	1 per bedroom. Additional spaces required where public facilities are provided.	100m <sup>2</sup> for a GFA of up to 500m <sup>2</sup> , 150m <sup>2</sup> for a GFA of up to 1000m <sup>2</sup> , 170m <sup>2</sup> for a GFA of up to 2000m <sup>2</sup>
C2: Residential institutions	Nursing and care homes	1 per 4 beds, plus 1 per 2 members of staff.	Space for 1 ambulance. Space for one pick up and drop off point to accommodate a minibus.
Class E: Commercial, business and service	E(a)(i) display or retail sale of goods, other than hot food, supermarkets, or food retail	1 per 20m <sup>2</sup> (for the first 1,000m <sup>2</sup> ), plus 1 per 35m <sup>2</sup> (for anything over 1,000m <sup>2</sup> )	50m <sup>2</sup> for a GFA of up to 500m <sup>2</sup> , 100m <sup>2</sup> for a GFA of up to 1000m <sup>2</sup> , 150m <sup>2</sup> for a GFA of up to 2000m <sup>2</sup>
	E(a)(ii) supermarket / food retail	1 per 14m <sup>2</sup> (for the first 1000m <sup>2</sup> ), plus 1 per 35m <sup>2</sup> (for anything over 1,000m <sup>2</sup> )	50m <sup>2</sup> for a GFA of up to 500m <sup>2</sup> , 100m <sup>2</sup> for a GFA of up to 1000m <sup>2</sup> , 150m <sup>2</sup> for a GFA of up to 2000m <sup>2</sup>
	E(b) sale of food or drink for consumption (mostly) on the premises	1 per 25m <sup>2</sup>	A minimum 50m <sup>2</sup> loading and unloading area. Any service areas must be laid out to allow an HGV to enter and leave the site in a forward gear.
	E(c)(i): Financial services	1 per 30m <sup>2</sup>	Banks, building societies and other financial services used by the public, no operational parking required.

Use class	Use	Number of parking spaces	Operational parking requirement
Class E: Commercial, business and service (continued)	E(c)(ii): Professional services	1 per 30m <sup>2</sup>	Standards to be determined on a site-by-site basis.
	E(c)(iii): Other appropriate services in a commercial, business or service locality	1 per 30m <sup>2</sup>	Standards to be determined on a site-by-site basis.
	E(d): Indoor sport, recreation, or fitness (not swimming pools)	1 per 2 participants, plus 1 per 5m <sup>2</sup> (for the first 1,000m <sup>2</sup> ), plus 1 per 22m <sup>2</sup> (for anything over 1,000m <sup>2</sup> )	50m <sup>2</sup> loading and unloading area. The requirement for additional coach parking will be agreed on a site-by-site basis.
	E(e) Medical or health services	5 per consulting room	Space for 1 pick-up and drop-off point for a car. Space for 1 ambulance.
	E(f) Creche, day nursery or day centre The parking requirement for these uses are cumulative. i.e., staff + visitors + parents = total	Staff: 2 per 3 staff	No operational parking required.
		Visitors: 1 per 7 staff	
		Parents: 1 per 12 children	
	E(g)i: Offices to carry out any operational or administrative functions	1 per 30m <sup>2</sup> in urban and edge of urban locations	30m <sup>2</sup> for a GFA of up to 100m <sup>2</sup> , 60m <sup>2</sup> for a GFA of between 100m <sup>2</sup> and 250m <sup>2</sup> , 75m <sup>2</sup> for a GFA of more than 250m <sup>2</sup> .
		1 per 25m <sup>2</sup> in rural areas	
	E(g)ii: Research and development of products or processes	1 per 30m <sup>2</sup> in urban and edge of urban locations	1 HGV space (45m <sup>2</sup> ) for the first 280m <sup>2</sup> , plus 1 additional HGV space per additional 500m <sup>2</sup> .
1 per 25m <sup>2</sup> in rural areas			

Use class	Use	Number of parking spaces	Operational parking requirement
Class E: Commercial, business and service (continued)	E(g)iii: Industrial processes	1 per 30m <sup>2</sup> in urban and edge of urban locations	1 HGV space (45m <sup>2</sup> ) for the first 280m <sup>2</sup> , plus 1 additional HGV space per additional 500m <sup>2</sup> .
		1 per 25m <sup>2</sup> in rural areas	
<p>F1 Learning and non-residential institutions</p> <p>F1(a) Provision of education</p> <p>The parking requirement for these uses are cumulative. i.e.: staff + visitors + parents = total</p> <p>*Schools located where adequate parking is available on-street or close by in a car park will not be required to provide on-site parking for parents.</p> <p>**Parking should only be provided for sixth form students where there is no alternative mode of travel available. The number of spaces provided should reflect the 'Hands Up Data' and School Travel Plan.</p>	Staff:	2 per 3 staff	<p>Space should be allocated for coaches, buses and minibuses which may be used either to bring children to school or for school trips. Where on-site provision can't be made, it must be clearly shown that on-street parking of coaches, buses and minibuses will not detrimentally affect the free-flow of traffic on the public highway. Refuse collection should be accommodated within the school site (where possible). For large schools, an on-site traffic flow system should be provided.</p>
	Visitors:	1 per 7 staff	
	Parents (reception, years 1 & 2):	1 per 12 pupils*	
	Parents (years 3,4,5 & 6):	1 per 20 pupils*	
	Parents (years 7,8,9,10 & 11):	1 per 30 pupils*	
	Parents sixth form (years 12 & 13):	1 per 30 pupils*	
	Sixth form students (years 12 & 13):	Standards to be determined on a site-by-site basis.**	
	Higher and further education staff:	1 per 2 staff	
	Higher and further education students:	1 per 15 students (all students and not the full-time equivalent)	
SEND schools	Standards to be determined on a site-by-site basis.	Standards to be determined on a site-by-site basis.	
F1 Learning and non-residential institutions	F1(d) Libraries	1 per 50m <sup>2</sup>	50m <sup>2</sup> loading and unloading area.
	F1(f) Public worship or religious instruction (or in connection with such use)	1 per 5m <sup>2</sup>	Adequate space for wedding and funeral vehicles either within the site or on-street.



Use class	Use	Number of parking spaces	Operational parking requirement
F2: Local community	F2(a) Retail (less than 200m <sup>2</sup> )	1 per 20m <sup>2</sup>	Standards to be determined on a site-by-site basis to reflect the types of vehicles likely to be servicing the retail facility.
	F2(a) Retail (200m <sup>2</sup> to 1,000m <sup>2</sup> )	1 per 20 m <sup>2</sup>	
	F2(a) Retail (1,000m <sup>2</sup> +) )	1 per 35m <sup>2</sup>	
F2: Local community (continued)	F2(b) Halls or meeting places for the principal use of the local community	1 per 5m <sup>2</sup>	50m <sup>2</sup> loading and unloading area. Space for 1 pick-up and drop-off point to accommodate a minibus.
	F2(c) Areas or places for outdoor sport or recreation	1 per maximum number of participants	50m <sup>2</sup> loading and unloading area. Space for 1 pick-up and drop-off point to accommodate a coach.
	F2(d) Indoor or outdoor swimming pools or skating rinks	1 per 2 participants, plus 1 per 5m <sup>2</sup> (for the first 1,000m <sup>2</sup> ), plus 1 per 22m <sup>2</sup> (for anything over 1,000m <sup>2</sup> )	50m <sup>2</sup> loading and unloading area. Space for 1 pick-up and drop-off point to accommodate a coach.
Sui Generis (in a class of its own)	Fuel stations (with shop)	1 per 2 employees	Standards to be determined on a site-by-site basis.
	Hot food takeaways (including drive throughs)	1 per 25m <sup>2</sup>	50m <sup>2</sup> loading and unloading area. For new buildings, service areas must be laid out to allow an HGV to enter and leave the site in a forward gear.
	Cinemas and concert halls	1 per 5 seats	50m <sup>2</sup> loading and unloading area. Space for 1 pick-up and drop-off point to accommodate a coach.

Use class	Use	Number of parking spaces	Operational parking requirement
Sui Generis (in a class of its own)	Dance halls, bingo halls and casinos	1 per 5 seats (for the first 1,000m <sup>2</sup> ), plus 1 per 22m <sup>2</sup> (for anything over 1,000m <sup>2</sup> )	50m <sup>2</sup> loading and unloading area. Space for 1 pick-up and drop-off point to accommodate a coach.
	Live music venues and theatres	1 per 5 seats (for the first 1,000m <sup>2</sup> ), plus 1 per 22m <sup>2</sup> (for anything over 1,000m <sup>2</sup> )	Standards to be determined on a site-by-site basis.

## 8.0 Disabled parking at non-residential developments

For non-residential developments, in addition to the standard parking spaces, a proportion of the parking spaces must be allocated for disabled users. The table below shows the number of disabled parking spaces that are required in relation to the number of standard parking spaces.

**Table 9: Minimum number of disabled parking spaces at non-residential developments**

Number of standard parking spaces:	Number of disabled parking spaces required:
1-15	1
16-33	2
34-50	2 +3% of total number of parking spaces
51-200	3 +3% of total number of parking spaces
201-500	4 +3% of total number of parking spaces
501-1,000	5 +3% of total number of parking spaces
1,001+	6 +3% of total number of parking spaces

- There may be circumstances where a higher number of disabled parking spaces is requested, for example where a development is proposed to provide facilities specifically for disabled people.
- For any mixed-use developments, (those that contain both residential and non-residential properties), the above standards should be adhered to.
- Disabled parking spaces should wherever possible be provided within 50 metres of the building or location that the disabled person is likely to be visiting.
- It is important that any disabled parking spaces that are provided are well designed to accommodate all disabled users' needs.
- Disabled parking spaces should be provided on firm ground with a level surface.
- A dropped kerb should be provided to allow access for a wheelchair user onto an adjacent footway. The dropped kerb should have a maximum upstand of 5mm.

See [appendix 32](#) for Disabled parking layouts at off-street locations.

See [appendix 33](#) for Disabled parking at on-street locations.

## 9.0 Parking for powered two-wheelers at non-residential developments

According to the [Department for Transport's statistical dataset](#), at the end of 2020, there were 6,900 motorcycles registered in Central Bedfordshire (which makes up approximately 3.5% of the registered vehicles in Central Bedfordshire). Where specific parking is not provided for powered two-wheelers, this could result in a powered two-wheeler either parking on a footway which could block access for pedestrians, or parking in a car parking space or cycle parking space, which then reduces the number of spaces available for other users. The key elements for powered two-wheeler parking are that it should be near, clear, secure, and safe to use. Motorcycle users will naturally look for parking opportunities as close as possible to their destination. 20 metres is desirable, beyond 50 metres and the use of an unofficial space can become prevalent.

**Table 10: Minimum number of powered two-wheeler parking spaces at non-residential developments**

Total number of car parking spaces	Number of powered 2-wheeler parking spaces
Up to 24	No spaces are required for existing developments where there are less than 24 car parking spaces.
	A minimum of 1 space for all new developments.
24+	1 space per 24 car parking spaces

- There may be circumstances where a higher number of powered two-wheeler parking spaces is requested, for example at educational establishments (particularly with pupils aged 16+), workplaces, shopping and leisure destinations, transport interchanges and locations where motorcycle themed events take place.
- Individual spaces should not be marked to make the most efficient use of the available space.
- Where other vehicles could try to park in a powered two-wheeler space, bollards or other measures should be installed to prevent this.
- Security is key and physical measures are highly sought after and attractive to users, as is natural surveillance.
- A fixed rail is the preferred type of security device to enable a motorcycle to be locked to it. The rail should be mounted at approximately 600mm above ground level to enable most wheels to be locked to it. Securing the rail to a wall or installing a waist-height upper rail minimizes the risk of tripping.
- The ground should have a limited gradient to facilitate manoeuvring, and to minimize the risk of a powered two-wheeler falling over.
- Covered parking is desirable for long-term parking (more than 2 hours) as it provides protection from weather and damage. Storage areas for clothing and equipment should also be provided.

See [appendix 36](#) for Powered two-wheeler parking layout.

## Glossary of Terms

### Car Clubs

Car clubs are short-term car rental services that allow members access to locally parked vehicles which are usually paid for by the hour or day. A car club offers an alternative to private car ownership for both individuals and businesses. Car clubs are most beneficial for those that need access to a car on an occasional basis and can work out to be more cost effective than owning a vehicle.

Some car clubs charge a membership fee (often paid monthly or annually) which allows an individual access to car club vehicles. Every time a car is used a fee is charged which is based on the type of vehicle borrowed, the length of time the vehicle is borrowed for, and the mileage incurred. Usual costs associated with owning a car (such as road tax, insurance, fuel, MOT, servicing, and breakdown cover) are usually covered by the membership fee.

There are two main models of car club – ‘back-to-base’ (where a vehicle is taken and returned to the same location) and one-way models. Once a signed-up member, a vehicle can be booked in advance online (sometimes via an app.). Depending on the system in place a vehicle is often unlocked using a smart card or smart phone.

### Central Bedfordshire Householder Travel Survey

Central Bedfordshire Council has conducted householder travel surveys every two years since 2010. The survey is an important part of monitoring performance against the Authority’s Local Transport Plan and to inform the development of future transport planning policies and activities.

The transport survey covers the following key issues:

- Ownership of cars, motorcycles, and cycles
- Travel patterns and attitudes
- Ease of access to key destinations
- Identifying transport related problems
- Use of, and attitudes towards, public and sustainable transport.
- Travelling to work, school, doctors, leisure activities, shops, and town centres.

The research is conducted via a quantitative telephone survey of 2,000 residents. Quotas are set based on the latest population data available to help ensure comparability with previous surveys and ensure that the survey sample is demographically representative of the local population. Quotas are set by gender, age, ethnicity, disability, urban/rural location. Interviews are conducted with no more than one person per household and interviews are conducted at different times of the day and different days of the week including evenings and weekends.

### Houses in Multiple Occupation (HMOs)

A house in multiple occupation is a building or part of a building that is occupied by more than one household where facilities such as bathrooms, cooking facilities and toilets are shared.

An HMO with up to 6 occupiers generally does not require planning permission – the government has granted planning permission in the form of permitted development rights. An HMO licence is



required to ensure the property meets minimum standards, it is not over-crowded, and the property is well managed. As planning permission is not required the parking standards in this document should be seen as guidance.

HMOs with seven or more occupiers requires planning permission. This is not a permitted development. Planning permission considers the impact of the change of use of the property on the surrounding area. HMO licensing is required as well as planning permission, to ensure the property meets minimum standards, it is not over-crowded, and the property is well managed. The parking standards contained in this document will apply to HMOs where there are 7 or more occupiers which will be investigated at the planning stage.

More information on Houses in Multiple Occupation can be found on our [website](#).

### **Swept Path Analysis**

Swept path analysis is the calculation and analysis of the movement and path of different parts of a vehicle when that vehicle is undertaking a turning manoeuvre. Usually, the largest vehicle or vehicle with the largest swept path that is likely to use a particular junction or bend will be tested to ensure that it is able to turn or make the manoeuvre. Swept path analysis is often completed using a software package.

### **Traffic Regulation Orders (TROs)**

A Traffic Regulation Order (TRO) is a legal process that enables highway authorities to restrict or prohibit the use of the public highway in line with the Road Traffic Regulation Act 1984. A TRO can only be proposed for the reasons set out in the legislation and a scheme can only be proposed if the regulations allow it to be signed and lined accordingly. Examples of schemes that require a TRO include:

- On-street parking restrictions
- Speed limits
- Weight limits
- One-way streets
- Banned turns
- Prohibition of driving

### **The Traffic Regulation Order (TRO) Process**

The implementation of a TRO follows a statutory process and is a legal document. The following process must be followed:

- Feasibility design (usually only completed for larger schemes or schemes where different options are proposed)
- Informal of pre-consultation (minimum 21 days, usually only completed for larger schemes or schemes where different options are proposed)
- Consideration of all comments received from the informal consultation (where completed). Report taken to Traffic Management Meeting to review the comments received and to decide if the scheme should continue to a statutory consultation, including any amendments to the initial consultation that may be considered.

- Proposed scheme design (incorporating comments received and any agreed amendments form the informal consultation stage, where completed).
- Statutory consultation (minimum 21 days), including the publication of notices.
- Consideration of all comments received.
- Report taken to Traffic Management Meeting with a recommendation as to whether the scheme should be implemented, amended, or not implemented based on the comments that are received during the statutory consultation. If the recommendation is for the scheme to be amended from what was advertised, this may require a further statutory consultation if the proposal is to add or extend any existing restrictions.
- Implementation of the TRO (making changes on site).
- Making of the TRO including sealing the order.
- Once the process is complete and the order is sealed, drivers who do not comply with these orders are committing an offence which could result in a fine, licence points or even disqualification from driving.

### **Traffic Management Meetings**

The Council has delegated various powers in relation to traffic matters to the Executive Member for Community Services. In making decisions on traffic matters the Executive Member is required to consider the views of local councillors and residents and to ensure that a notice is provided of any decisions to be taken. To provide a forum for these decisions the Executive Member has determined that a Traffic Management Meeting will take place when necessary to discuss proposals or concerns relating to several matters, which include the following:

- Public petitions
- Speed limits
- Traffic calming measures
- Waiting restrictions
- Any other proposed highway improvement scheme that requires a Traffic Regulation Order or Public Notice.

### **Waiting restrictions - double yellow lines**

Double yellow lines are restrictions that mean 'no waiting at any time', unless there are signs that specifically indicate seasonal restrictions. The phrase 'no waiting at any time' is usually used in public notices and legal documentation instead of referring to double yellow lines. The restriction means that a motorist is permitted to stop for a short period of time, for example to pick up or drop off a passenger, but not for any longer which would constitute waiting. The exception to this is when there are loading restrictions, which are shown by a yellow marking on the kerb or edge of carriageway which prevents any vehicle from stopping. Loading restrictions may always operate, or at certain times and days which are indicated on upright signs. Waiting and loading restrictions apply to the carriageway, and any pavement or verge behind the restriction.

### **Waiting restrictions - single yellow lines**

Like a double yellow line, a single yellow line is a restriction that means 'no waiting'. The difference is that a single yellow line does not apply all the time, and will apply for certain days, times, or a combination of both. A single yellow line will be accompanied by upright signs which specify the days and times that the restriction is in operation. Loading restrictions may also be in place with a single yellow line. Parking is permitted outside the specified times of operation.

## Appendix 1: Vehicle dimensions

The following are parking bay dimensions required for typical vehicles when stationary in a perpendicular parking space. These dimensions refer to standing space only and do not take account of access, manoeuvring space, space required for loading / unloading or for the provision of electric vehicle charging points.

Vehicle type	Length	Width
Cycle	2 metres	1 metre
Powered two-wheeler	2.5 metres	1.4 metres
Car	5 metres	2.5 metres
Transit van	7 metres	3 metres
Long-wheelbase van	9 metres	3 metres
Minibus (17-seater)	9 metres	3 metres
Ambulance	9 metres	3.5 metres
Refuse collection vehicle	11 metres	3.5 metres
Rigid vehicle	12 metres	3.5 metres
Fire appliance (aerial platform)	13 metres	3.5 metres
Bus (29 seats)	13 metres	3.5 metres
Coach (60 seats)	13 metres	3.5 metres
Articulated vehicle	17 metres	3.5 metres

## Appendix 2: Cycle parking

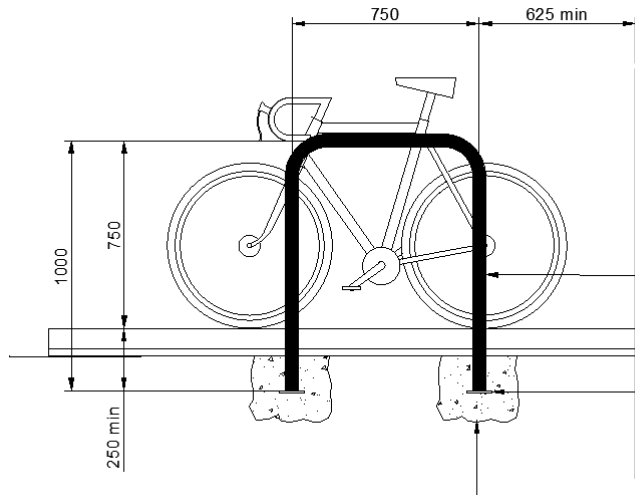

Sheffield stand. A polyurethane finish is preferred to prevent cycles being chipped and to prolong the life of the stand.

Baseplate to prevent stands being pulled out.

ST1 concrete 300mm<sup>2</sup> cube or equivalent.

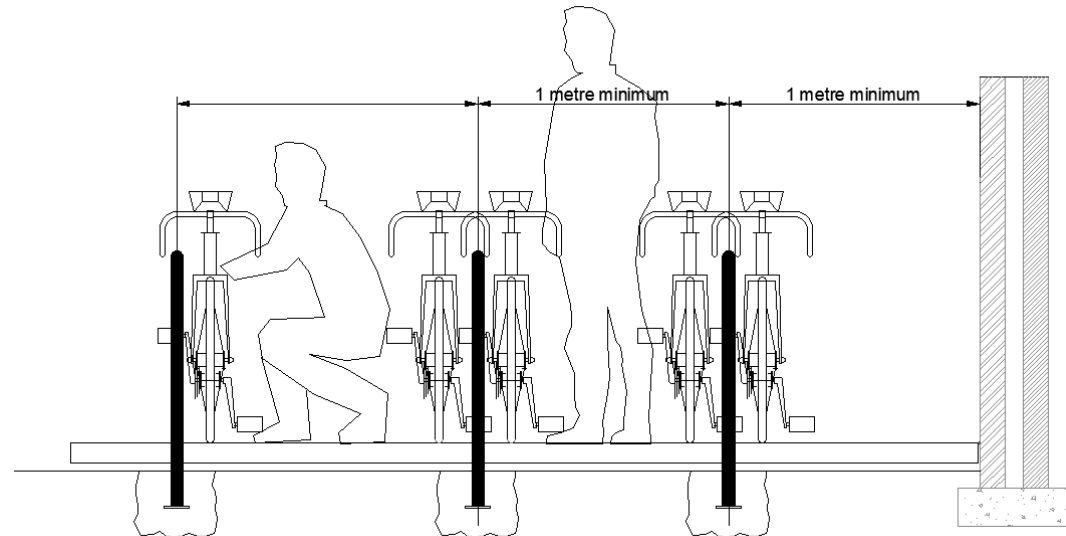
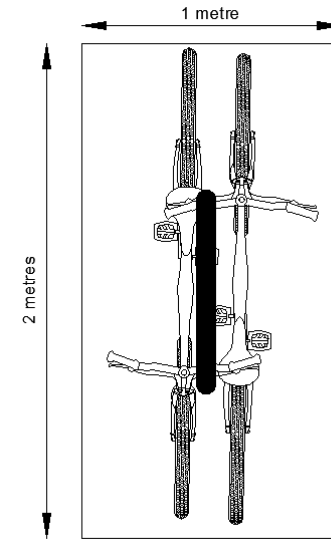

## Appendix 3: Cycle parking layouts

Allowing additional space at the end of a row of cycle stands will enable a cargo bike or bike with a trailer attached to be parked.

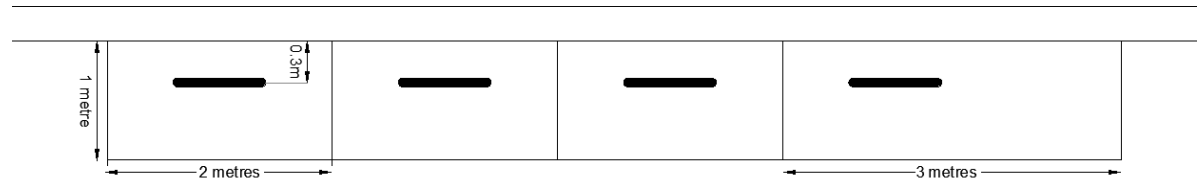
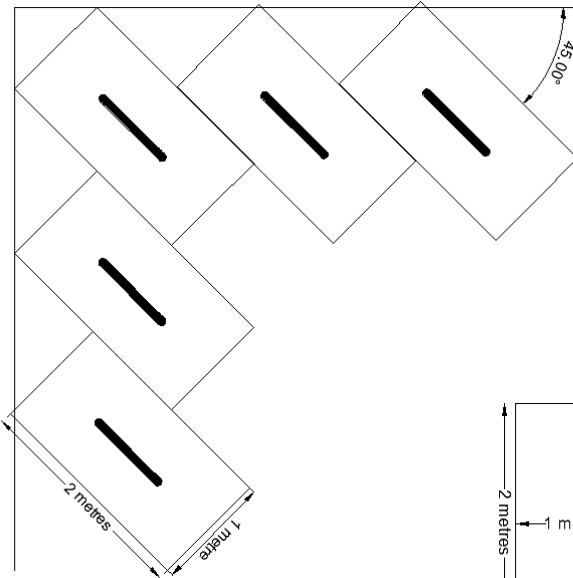

Layout where cycle stands are installed parallel to a wall or boundary and are intended to be used on one side only.

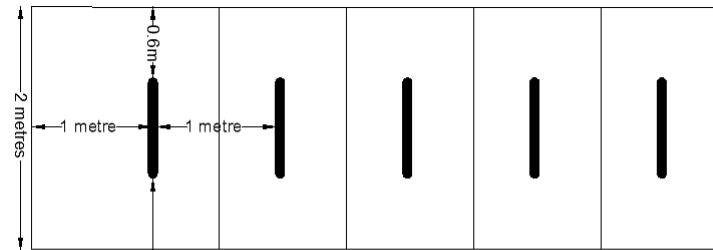

Allowing additional space at the end of a row of cycle stands will enable an adapted cycle or tricycle to be parked.

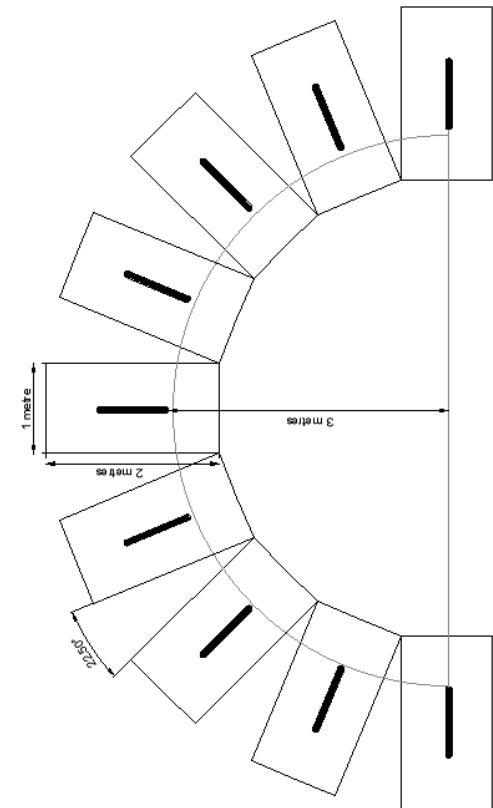
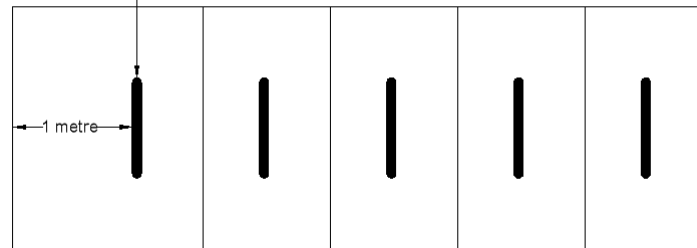



## Appendix 4: Locations where developments within 500 metres of Arlesey railway station can use the relaxed parking standards

Measuring point: Arlesey station building.

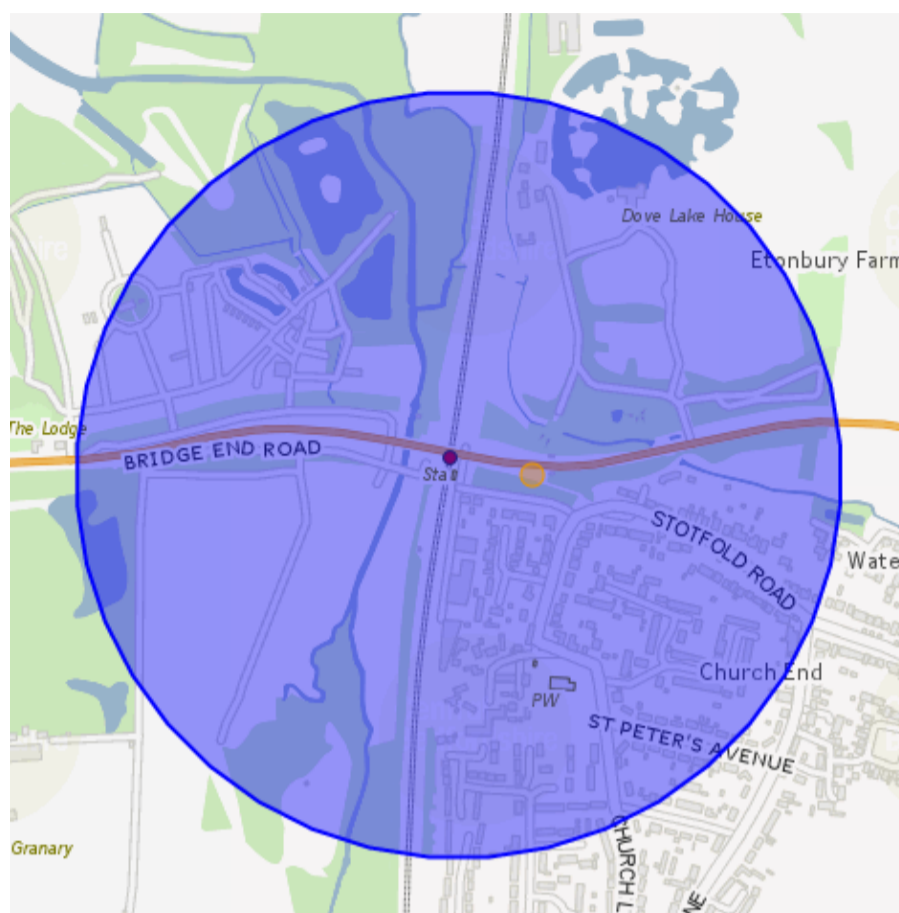

Carter's Way	Etonbury Farm	Riverside	The Poplars
Chase Close	Henlow Bridge Lakes	Saffron Close	Vicarage Close
Church End	Old Oak Close	St Peter's Avenue	Any other land where a development is proposed within 500 metres of Arlesey station building, providing that there is a pedestrian route between the development and Arlesey station.
Church Lane (from the junction with Stotfold Road and Old Oak Close to the junction with Glebe Avenue)	Pix Court	Stotfold Road (from the junction with Church Lane, to the junction with House Lane)	

## Appendix 5: Locations where developments within 500 metres of Biggleswade town centre can use the relaxed parking standards

Measuring point: The war memorial, Market Place.

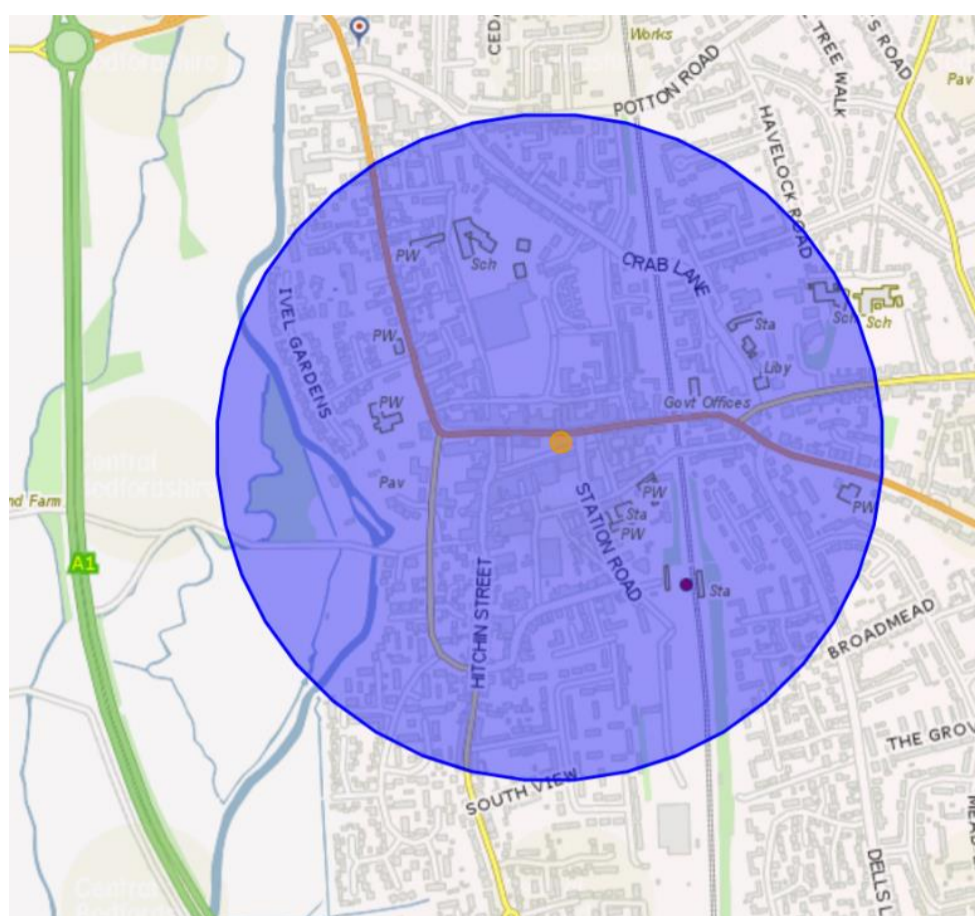

Apple Tree Close	Dilley Croft	Osprey Road (from Teal Road junction to the junction with Bittern Drive)	The Grove
Back Street	Ely Croft	Palace Street	Wells Court
Barn Field Close	Empire Close	Rose Lane	
Berkeley Close	Foundry Lane	Saffron Road	
Blunham Road	Ivel Gardens	Sand Lane	
Bonds Lane	Hereford Grove	Sandpiper Close	
Brigham Gardens	High Street	Shortmead Street (High Street / St Andrew's Street junction to the junction with Parkland Place)	
Bunyan Road	Hitchin Street (from Teal Road / Saffron Road junction to the junction with Southview)	South View	
Byron Close	Holme Crescent	Station Road	
Chapel Fields	Lawrence Road (from Lindsell Crescent junction to the junction with Crab Lane)	St Andrews Close	
Chestnut Avenue	Lincoln Crescent	St Andrew's Street	
Church Street	London Road (from High Street junction to the junction with Dilley Croft)	Sun Street (from St John's Street junction to Rose Lane junction)	
Claremont Court	Market Place	Teal Road	
Coppice Mead	Mead End	The Baulk (from London Road / High Street junction to the junction with The Avenue)	
Crab Lane	Mill Close	The Close	
Dells Lane (from London Road junction to Broadmead junction)	Mill Lane	The Dells	

## Appendix 6: Locations where developments within 500 metres of Biggleswade railway station can use the relaxed parking standards

Measuring point: Biggleswade station building

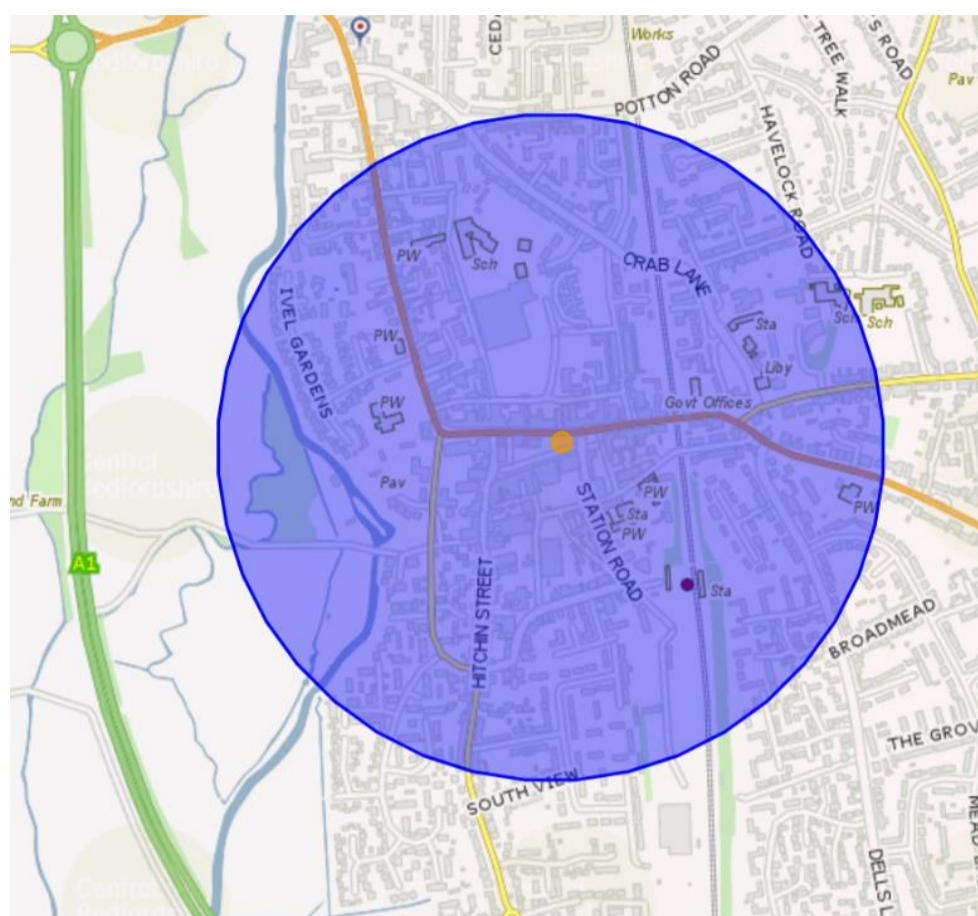

Apple Tree Close	Coppice Mead	London Road (from High Street junction to the junction with Drove Road)	St Andrews Close
Back Street	Crab Lane	Market Place	St Andrew's Street
Barn Field Close	Dells Lane (from London Road junction to Oak Crescent junction)	Mead End	Sun Street (from St John's Street junction to Rose Lane junction)
Berkeley Close	Dilley Croft	Mill Close	Teal Road
Blunham Road	Ely Croft	Mill Lane	The Balk
Bonds Lane	Empire Close	Palace Street	The Dells
Brigham Gardens	Foundry Lane	Rose Lane (from High Street junction to the junction with Sun Street / Crab Lane)	The Grove
Bunyan Road	Ivel Gardens	Saffron Road	Wells Court
Byron Close	Hereford Grove	Sand Lane	
Chapel Fields (from the junction with Church Street to 'The Bungalow')	High Street	Sandpiper Close	
Chestnut Avenue	Hitchin Street (from Teal Road / Saffron Road junction to the junction with Berkeley Close)	Shortmead Street (High Street / St Andrew's Street junction to the junction with Ivel Gardens)	
Church Street	Holme Crescent	South View	
Claremont Court	Lincoln Crescent	Station Road	



## Appendix 7: Locations where developments within 500 metres of Dunstable town centre can use the relaxed parking standards

Measuring point: The point where High Street North, High Street South, West Street and Church Street meet.

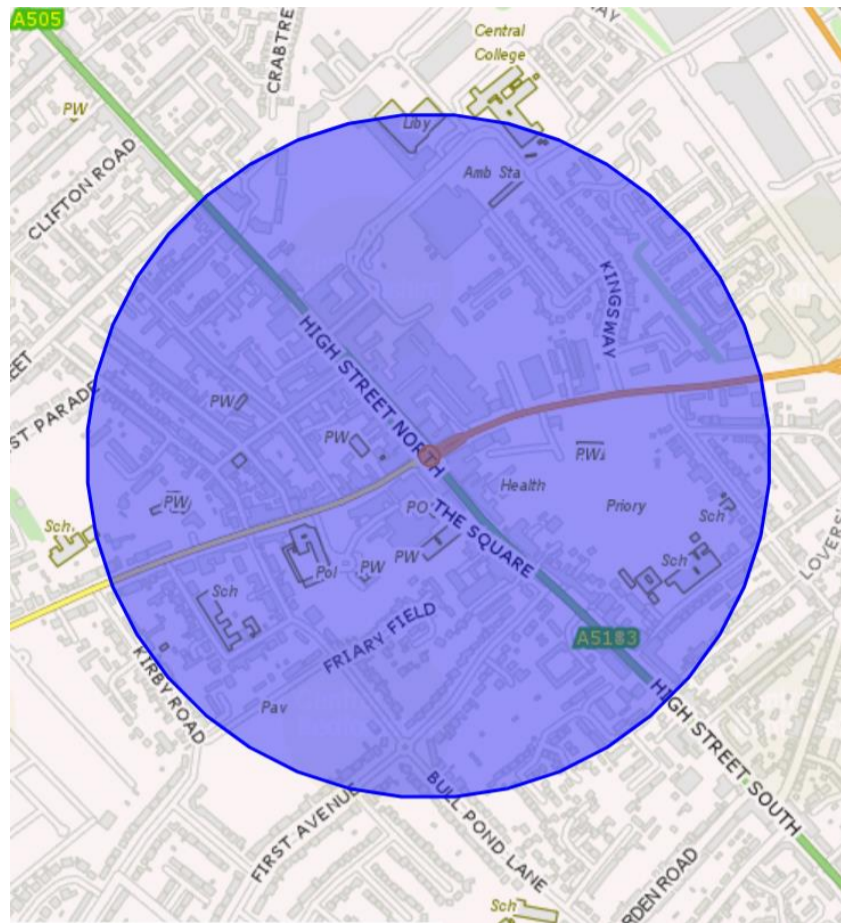

Albion Street	Edward Street	Matthew Street	Sugden Court
Bernard Close	Eleanor's Cross	Nicholas Way	The Mall
Britain Street	Friars Walk	Princes Street (West Street junction to the junction with West Parade)	Vernon Place
Bull Pond Lane (Burr Street / Icknield Street junction to the junction with First Avenue and Friars Walk)	Friary Field	Priory Road	Victoria Street (West Street junction to the junction with Union Street)
Burr Street	High Street North (Church Street / West Street junction to the junction with Winfield Street)	Queensway	The Square
Chadwick Close	Icknield Street	Regent Street	West Street (High Street North / High Street South junction to the junction with Burr Street)
Court Drive	Kingscroft Avenue	St Mary's Gate	Winfield Street
Dorchester Close	Manchester Place	St Peters Road	

## Appendix 8: Locations where developments within 500 metres of the Luton and Dunstable guided bus way stop adjacent to Portland Ride can use the relaxed parking standards

Measuring point: Guided bus way stop adjacent to Portland Ride

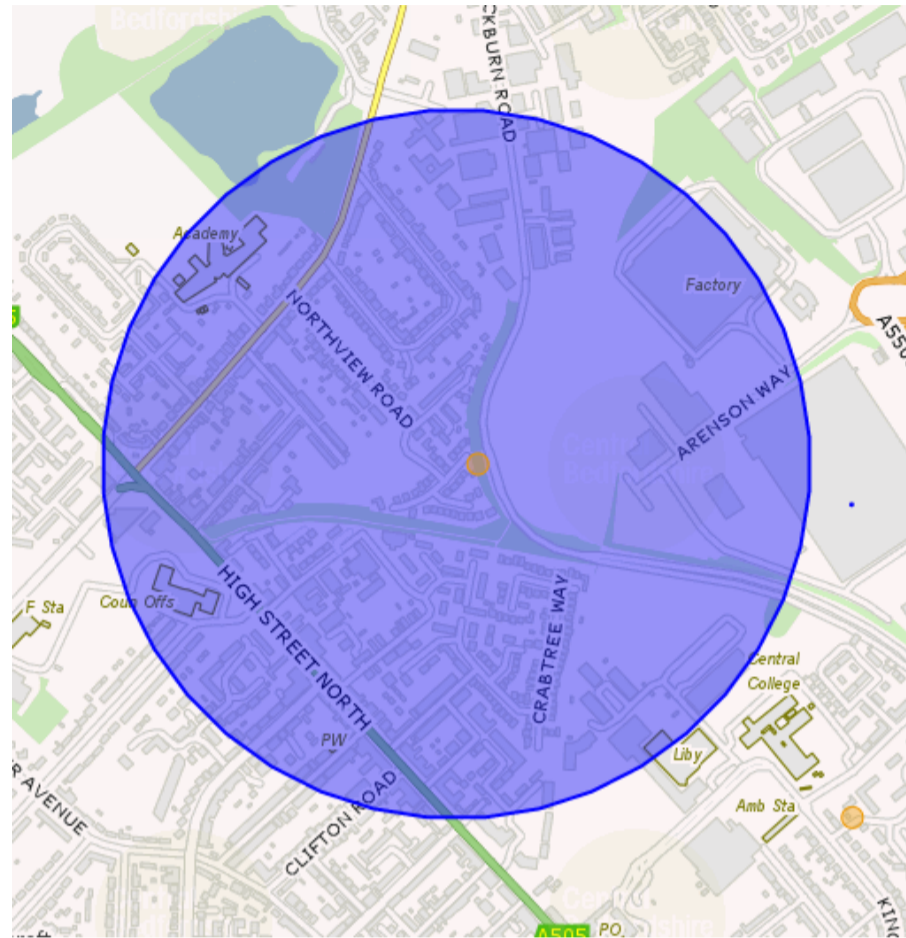

### Locations in Dunstable

Ashton Road	Frances Drive	Olma Road	Sidings Way
Capron Road	George Street	Park Street	Tavistock Street
Court Drive	Gilpin Street	Printers Way	Any other land within 500 metres of the guided busway stop adjacent to Portland Ride
Crabtree Way	High Street North (from the junction with Brewers Hill Road and Houghton Road to the junction with Ashton Road)	Readers Close	

### Locations in Houghton Regis

Blackburn Road	Mayer Way	Portland Ride	
Douglas Crescent	Northview Road		



**Appendix 9: Locations where developments within 500 metres of the Luton and Dunstable guided bus way stop adjacent to College Drive can use the relaxed parking standards**

Measuring point: Guided bus way stop adjacent to College Drive

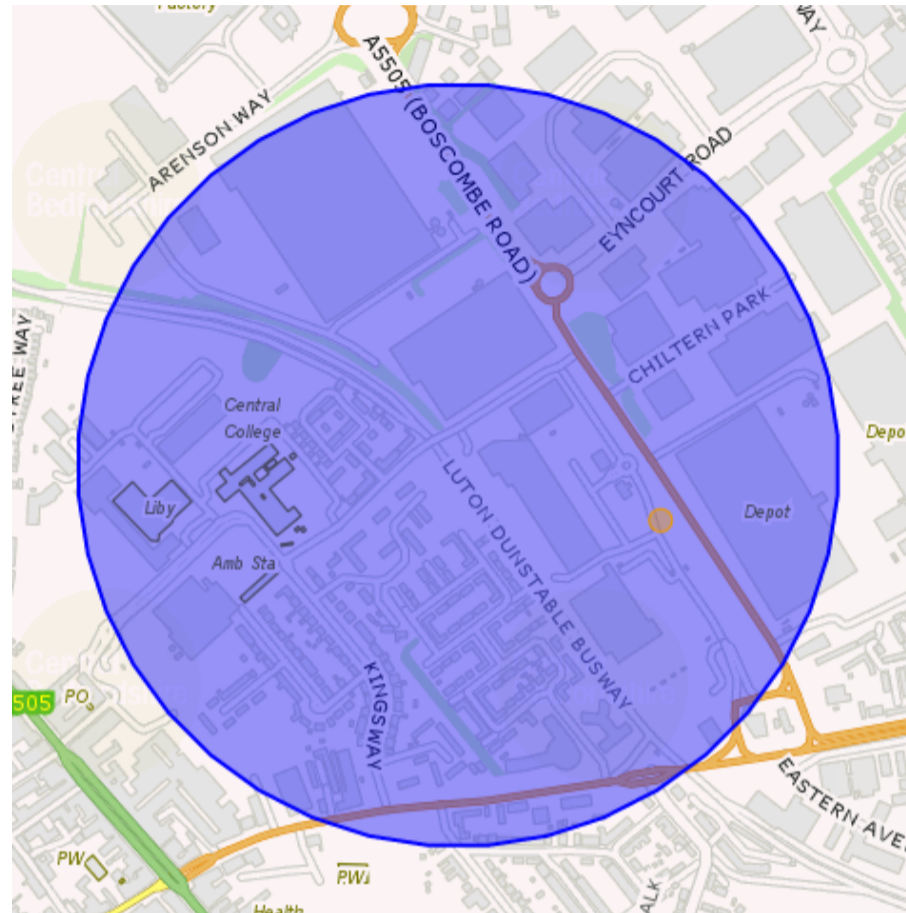

Bagshawe Way	Dorchester Close	Fauna Field	Kingsway
Bernard Close	Duchess Court	Hazel Mead	Princes Court
Boscombe Road	Dukeminster Road	Holly Acre	Queens Court
Chiltern Park	Earls Court	Kings Court	Tilling Green
Court Drive	Eyncourt Road	Kingscroft Avenue	Verey Road
			Any other land within 500 metres of the guided busway stop adjacent to College Drive

## Appendix 10: Locations where developments within 500 metres of the Luton and Dunstable guided bus way stop adjacent to Dukeminster Close can use the relaxed parking standards

Measuring point: The junction of Dukeminster Close with Church Street

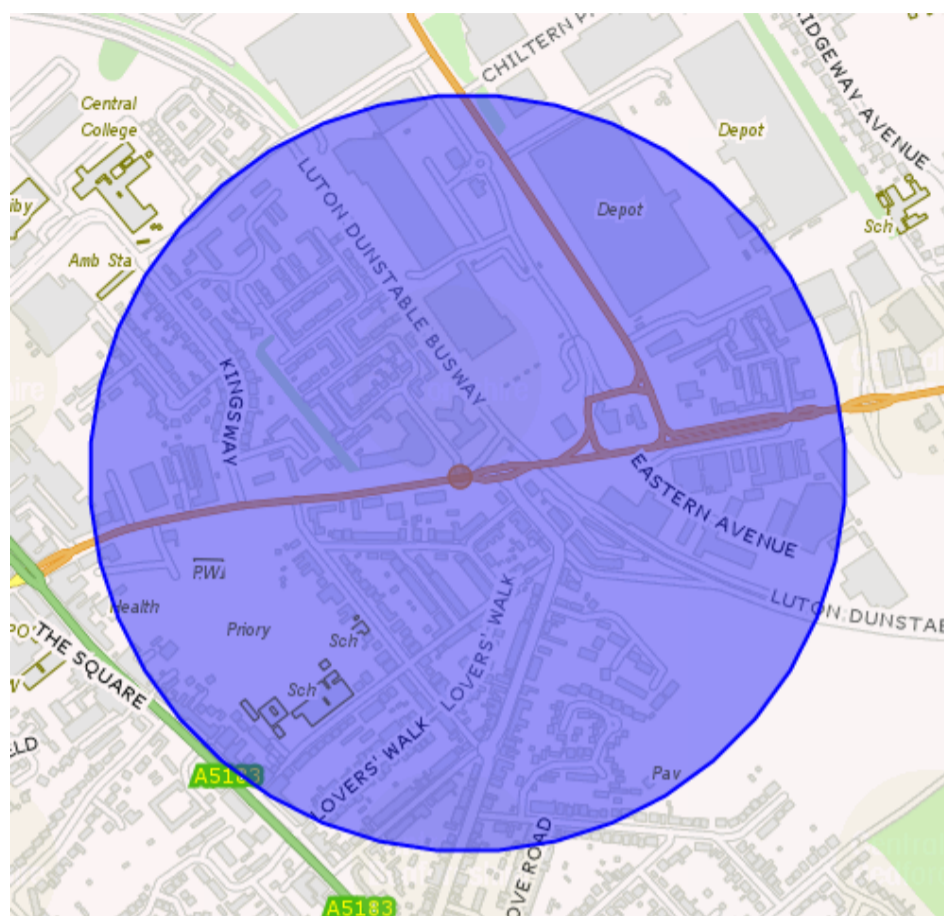

Allen Road	Dorchester Close	Kingsbury Court	Station Road
Bagshawe Way	Downs Road	Kingscroft Avenue	St Peter's Road
Bernard Close	Dukeminster Road	Kingsway (from the junction with Church Street to the junction with College Drive)	Tilling Green
Boscombe Road (from the junction with Luton Road to the junction with Eyncourt Road)	Eastern Avenue	Long Hedge	The Mall
Bramley Court	Englands Lane	Lover's Walk	Any other land within 500 metres of the guided busway stops adjacent to Church Street and Station Road
Britain Street	Fauna Field	Priory Road	
Church Close	Great Northern Road	Richard Street	
Church Walk	King Street	Russett Way	

**Appendix 11: Locations where developments within 500 metres of the Luton and Dunstable guided bus way stop adjacent to Jeans Way can use the relaxed parking standards**

Measuring point: Guided bus way stop adjacent to Jeans Way

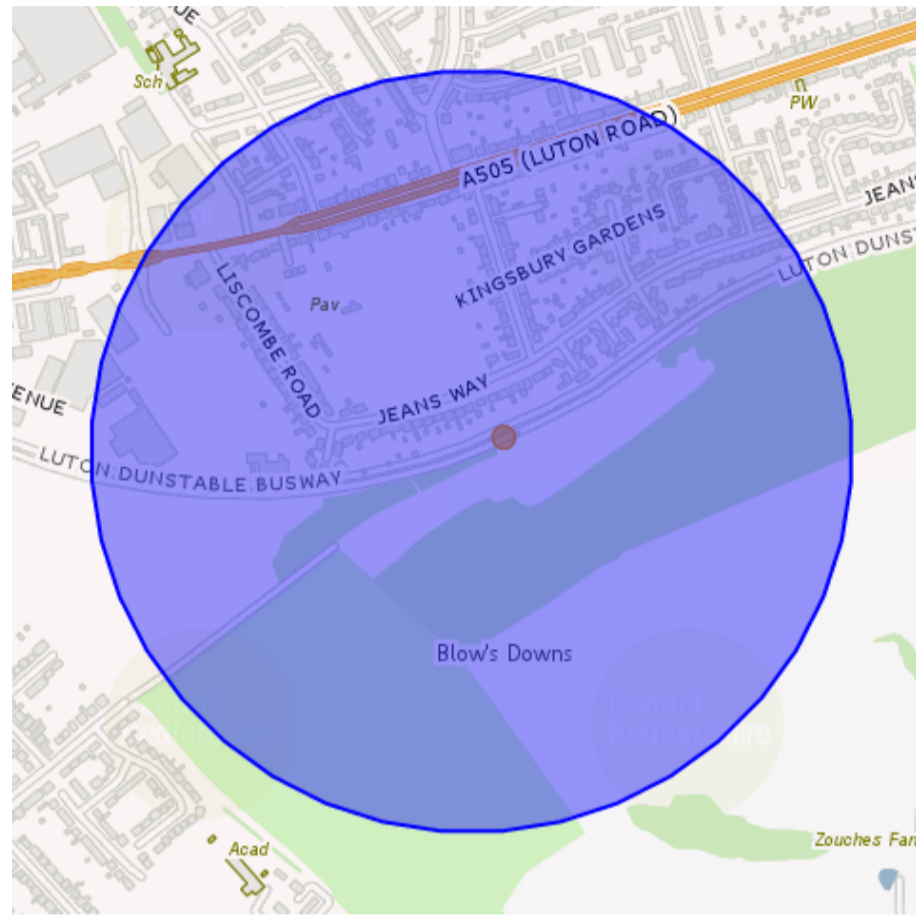

Dale Road	Jeans Way	Liscombe Road	The Retreat
Fairfield Close	Kingsbury Avenue	Luton Road (from the junction with Liscombe Road to the junction with Dale Road)	Woodford Road (from the junction with Luton Road to the junction with Buckwood Aveune)
Fairfield Road	Kingsbury Gardens	Ridgeway Avenue (from the junction with Luton Road to the junction with Western Way)	Any other land within 500 metres of the guided busway stop adjacent to Jeans Way

## Appendix 12: Locations where developments within 500 metres of Flitwick town centre and railway station can use the relaxed parking standards

Measuring point: Flitwick Station building.

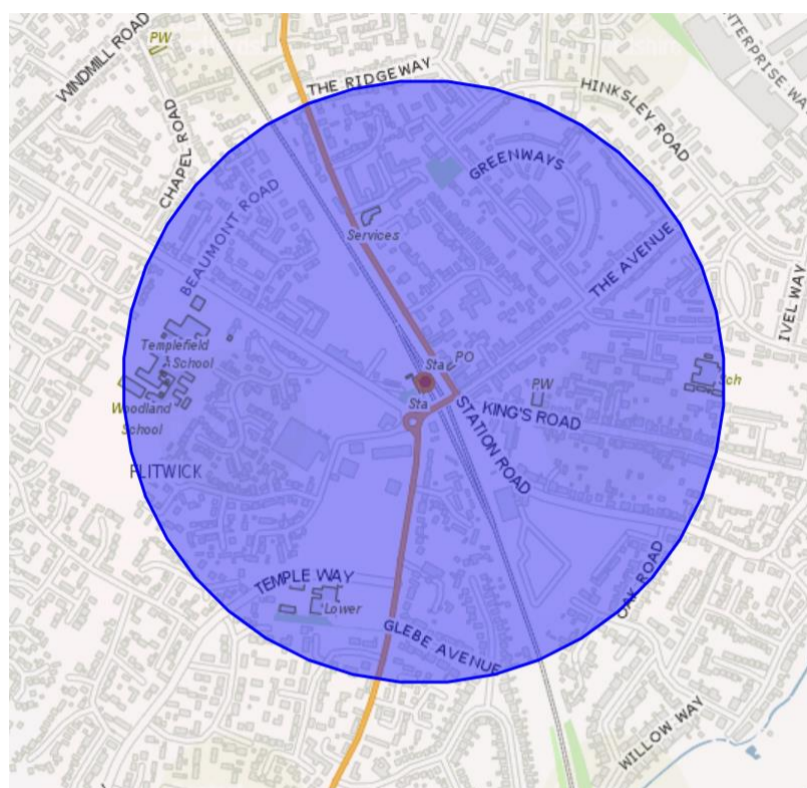

Beaumont Road	Glebe Avenue	Kendal Drive	The Avenue
Beech Road	Grasmere Close	Lyll Close	The Croft
Brookes Road	Greenways	Malham Close	The Hawthorns
Catherine Road	Hawes Close	Oak Road	Thirlmere Gardens
Coniston Road	Highlands	Pilgrims Close	
Derwent Rise	High Street (from the roundabout with The Avenue and Station Road to the junction with The Ridgeway)	Sheepfold Hill	
Dunstable Road (from the roundabout with Coniston Road, The Avenue and Steppingley Road to the junction with Lovet Road)	Hilldene Close	Station Road (from the junction with The Avenue to the junction with Oak Road)	
Easton Road	Kingsmoor Close	Steppingley Road (from the roundabout with The Avenue and Dunstable Road to the junction with Chapel Road)	
Fern Gardens	King's Road (from the junction with Station Road to the junction with Queens Close)	Temple Way (from the junction with Dunstable Road to the junction with Falcon Crescent)	



## Appendix 13: Locations where developments within 500 metres of Leighton Buzzard town centre can use the relaxed parking standards

Measuring point: Market Cross, High Street Leighton Buzzard.

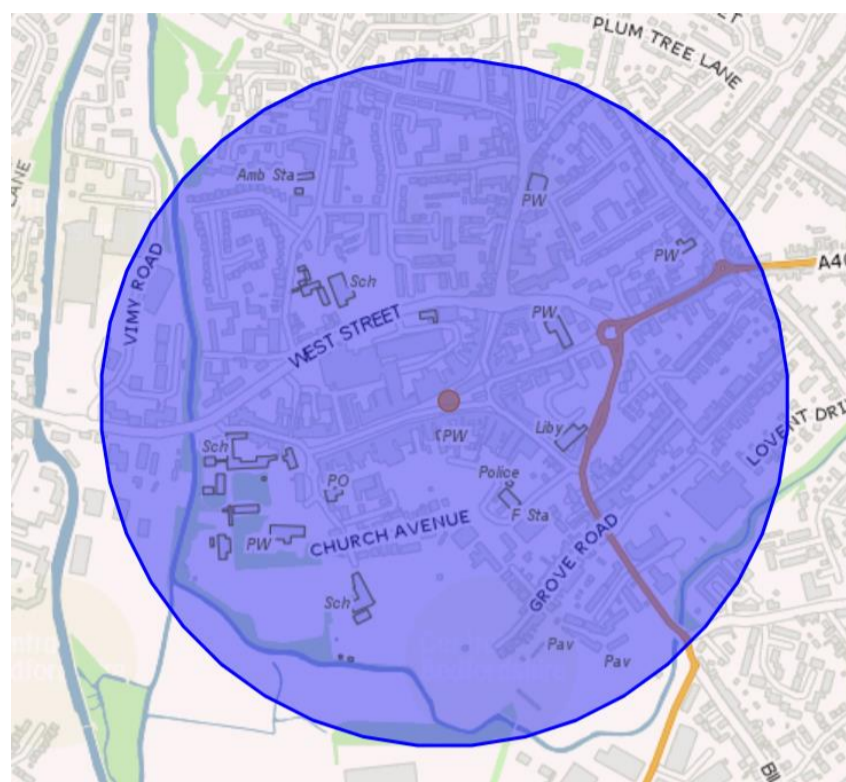

Albany Road	Doggett Street	High Street	St Andrews Close
Baker Street	Dudley Street	Lammas Walk	St Andrews Street
Bassett Road	Duncombe Drive	Lake Street	Vimy Road (from the junction with Leighton Road to the junction with the service road behind Homebase)
Bedford Street	Grove Place	Leston Road	Water Lane
Bridge Street	Grove Road	Lindler Court	West Street
Church Avenue	Hartwell Crescent	Mill Road	Windsor Avenue
Church Square	Hartwell Grove	Millstream Way	
Church Street (from the junction with North Street to the junction with Ashwell Street)	Hockliffe Street	Pulford Road	



## Appendix 14: Locations where developments within 500 metres of Leighton Buzzard railway station can use the relaxed parking standards

Measuring point: Station main building.

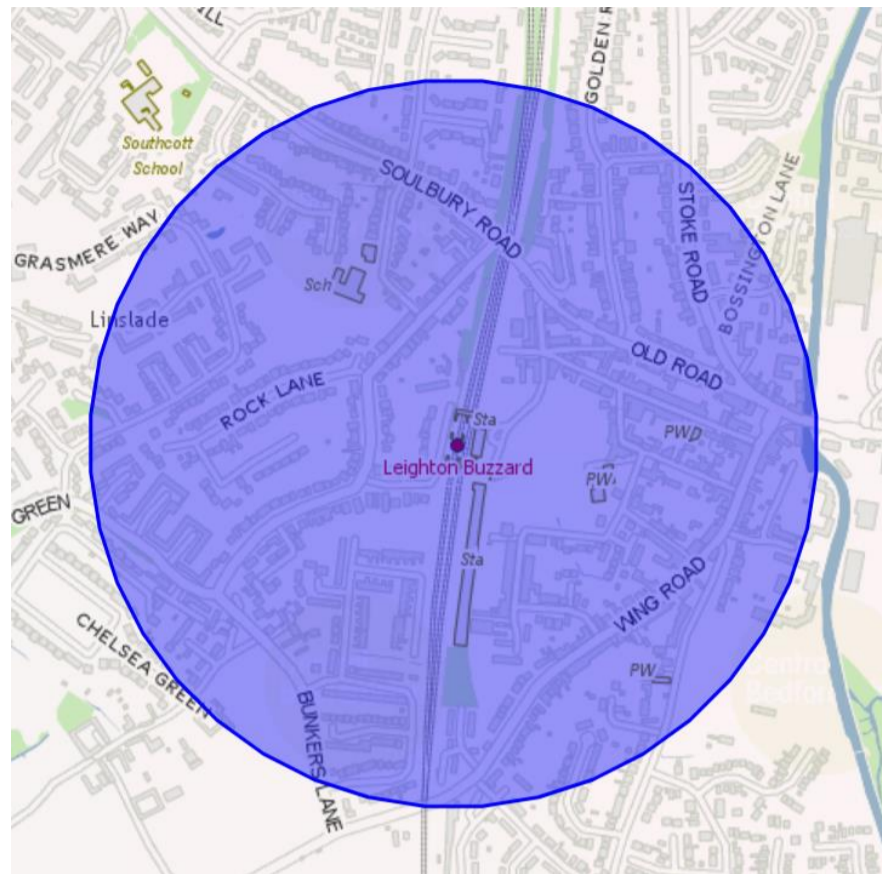

Apple Tree Close	Leopold Road	St Mary's Way (from the junction with Soulbury Road to the junction with Hawthorn Close)	Wing Road (from the junction with Old Road and Leighton Road to the junction with Bunkers Lane)
Beech Grove	Mentmore Road (from the junction with Wing Road to the junction with Camberton Road)	Ship Road	Victoria Road
Bunkers Lane	Mowbray Drive	Soulbury Road (from the junction with Old Road to the junction with Mowbray Drive)	Waterloo Road
Church Road	New Road	Southcott Village (from the junction with Bunkers Lane to the junction with Chelsea Green)	Vicarage Road
Epsom Close	Old Road	Southcourt Avenue	Vicarage Gardens
Faulkner's Way	Orchard Drive	Springfield Road	Waterside Mews
Grange Close	Pine Crest Mews	Stephenson Close	
Grasmere Way	Primrose Gardens	Woodside Way	
Hanover Court	Rock Close	Stoke Road (from the junction with withhold Road to the junction with Rosebery Avenue)	
Ivester Court	Rock Lane	The Gables	
Ledburn Grove	Rosebury Avenue	The Wharf	

## Appendix 15: Locations where developments within 500 metres of Sandy railway station can use the relaxed parking standards

Measuring point: Station main building.

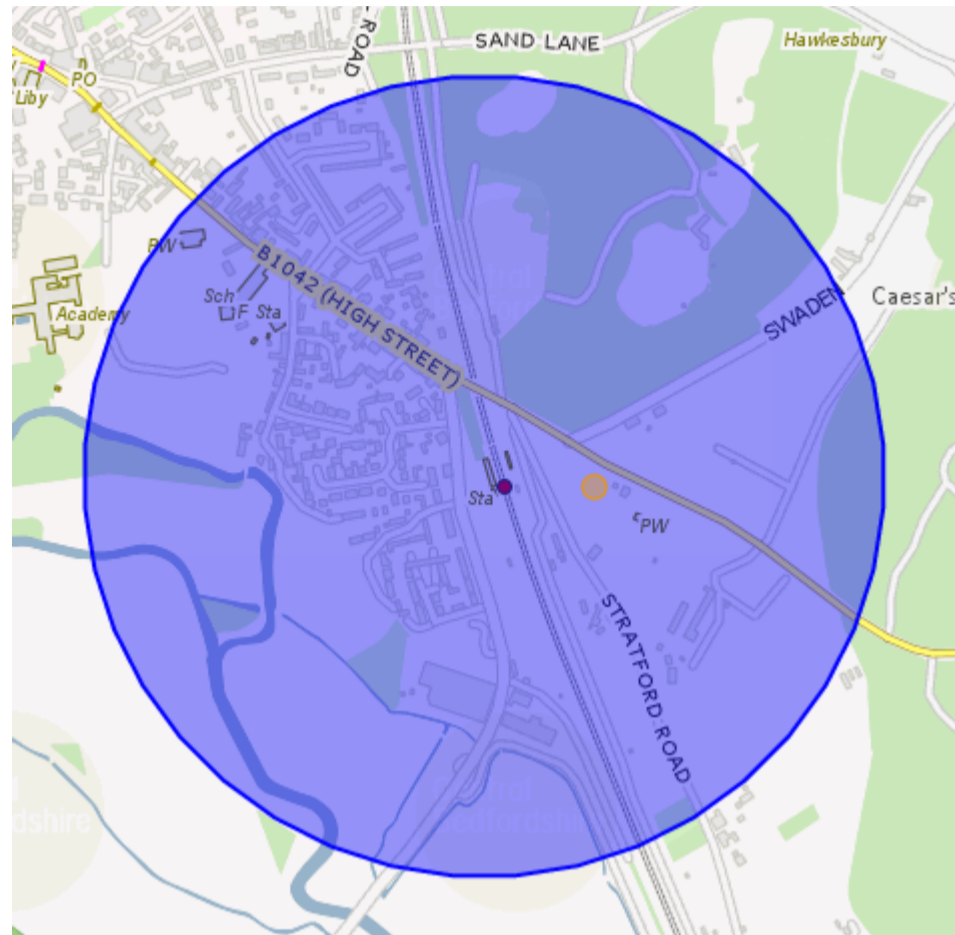

Centurion Walk	New Road (from the junction with Station Road to the bridge over the river Ivel)	St Swithun's Way	Willow Rise
Cherrycroft	Ongley Court	Spencer Road	Woolfield
High Street (from the junction with Potton Road and Station Road to the junction with Park Road)	Peel's Place	Stonecroft	Any other land where a development is proposed within 500 metres of Sandy station building, providing that there is a pedestrian route between the development and Sandy station.
Ivel Road	Potton Road (from the junction with Station Road and High Street for 600 metres)	Stratford Road (from the junction with Potton Road to No. 1 Stratford Road)	
Ivel View	Rectory Court	Swaden (from the junction with Potton Road to the junction with Everton Road and Sand Lane)	

## Appendix 16: Residential parking layouts – driveway for a single vehicle

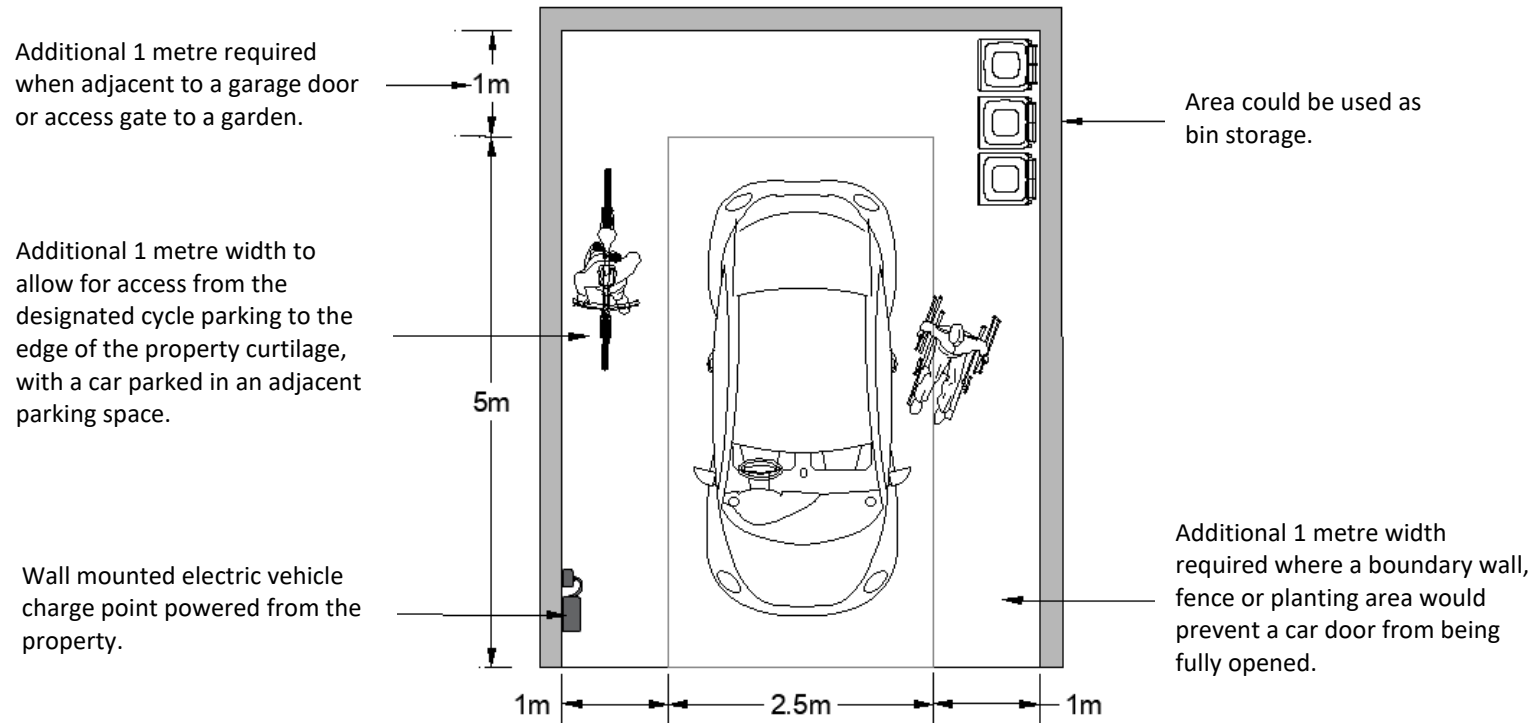

## Appendix 17: Residential parking layouts – one parking space to the front of a property

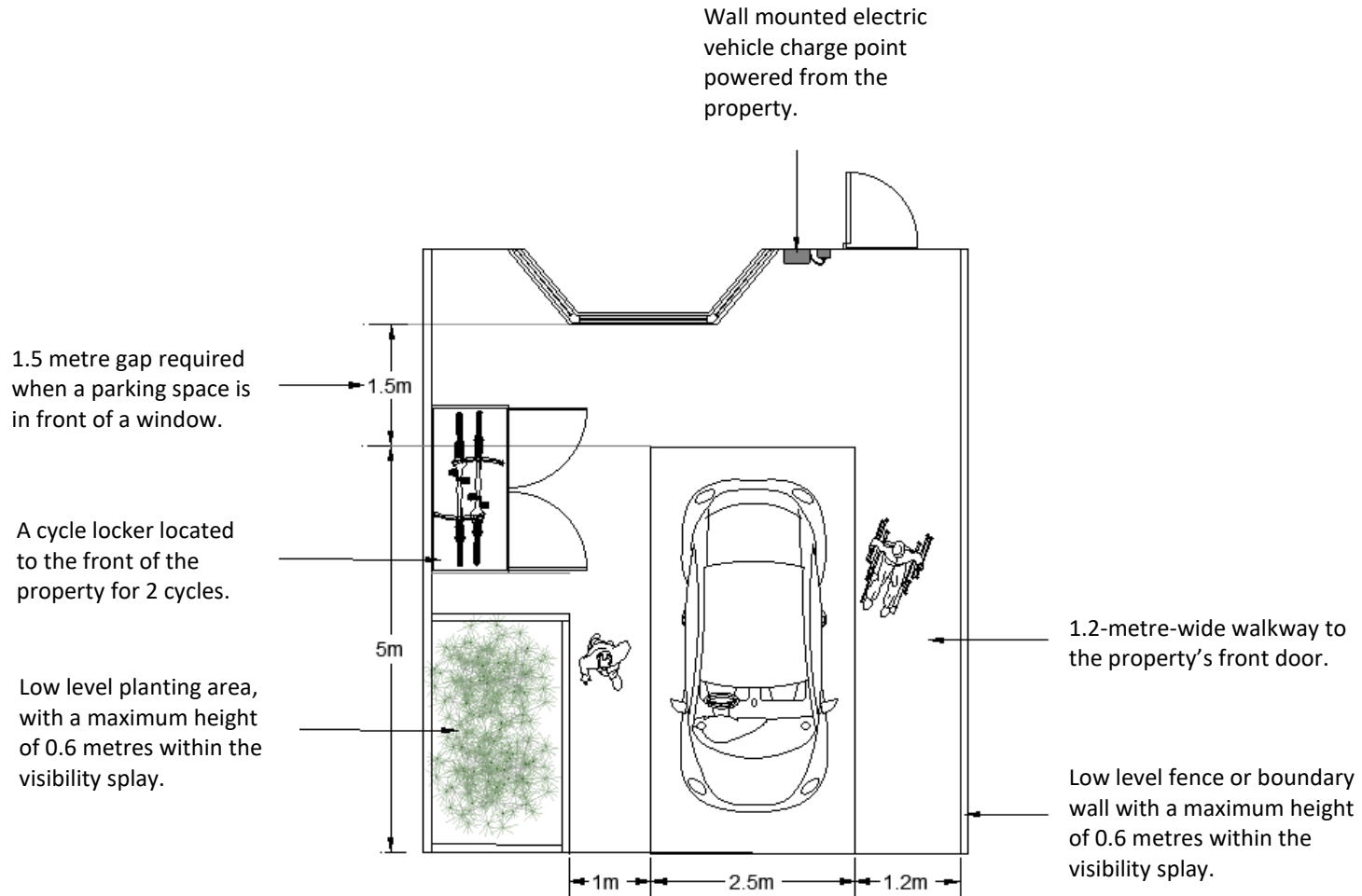

## Appendix 18: Residential parking layouts – driveway for two vehicles adjacent to one another

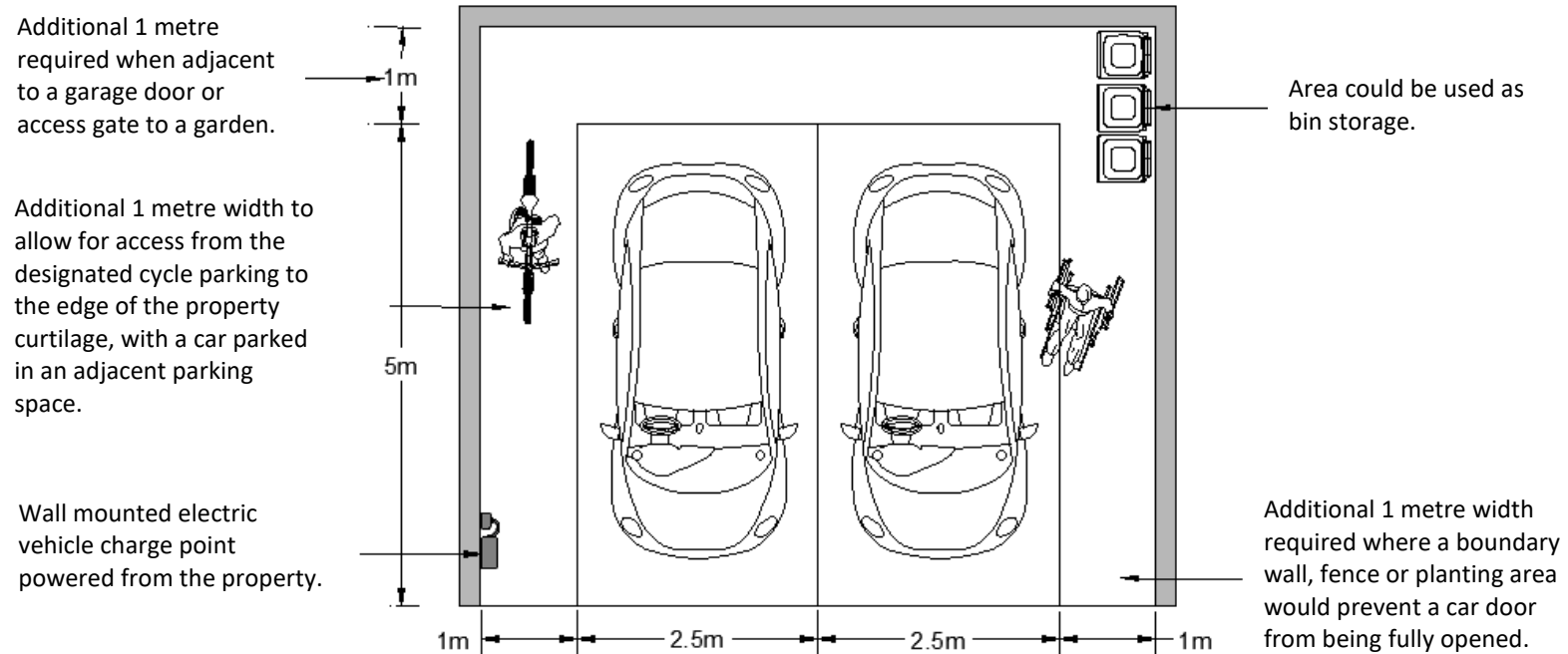

## Appendix 19: Residential parking layouts – two parking spaces to the front of a property

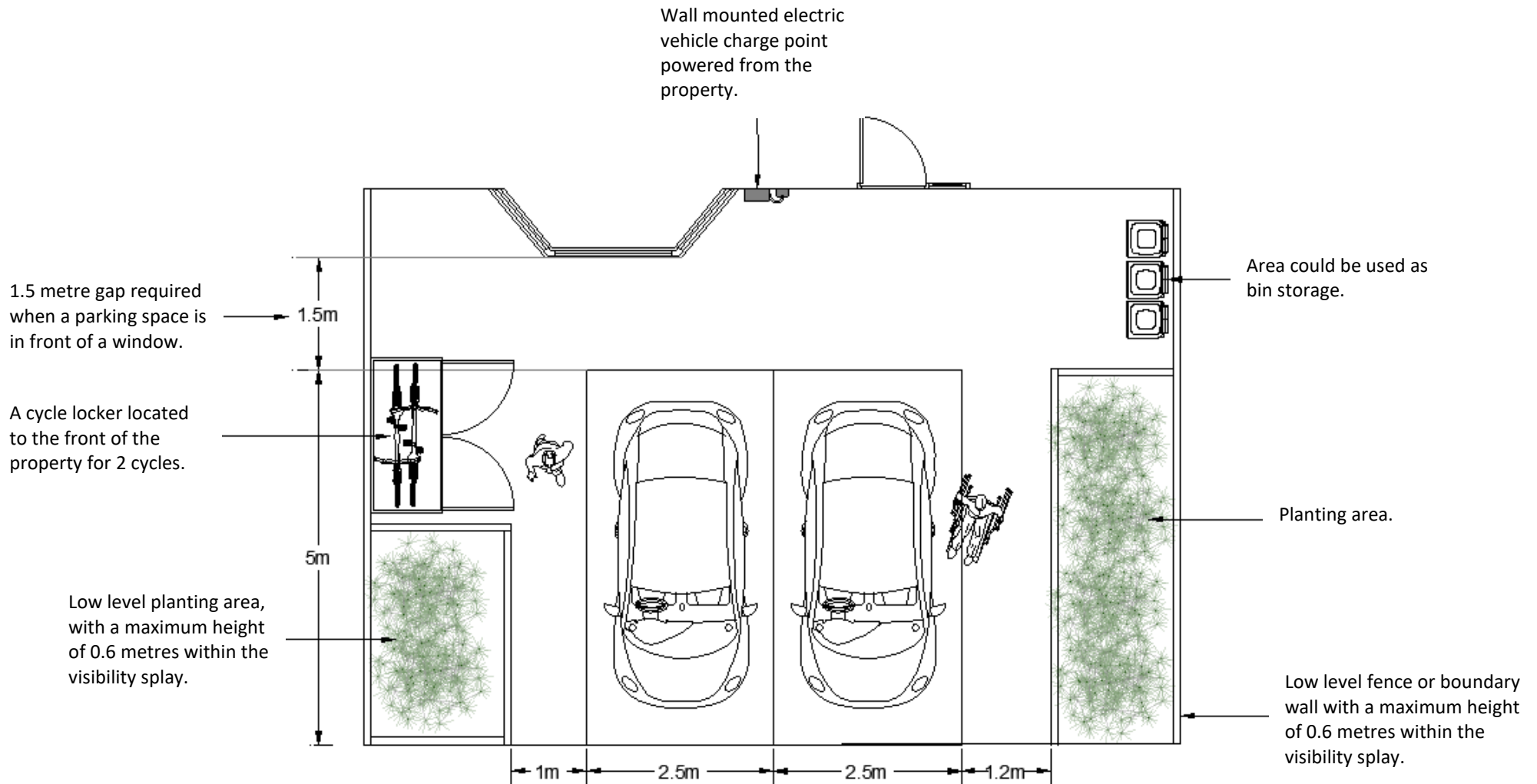



## Appendix 20: Residential parking layouts – driveway for two vehicles in a tandem arrangement

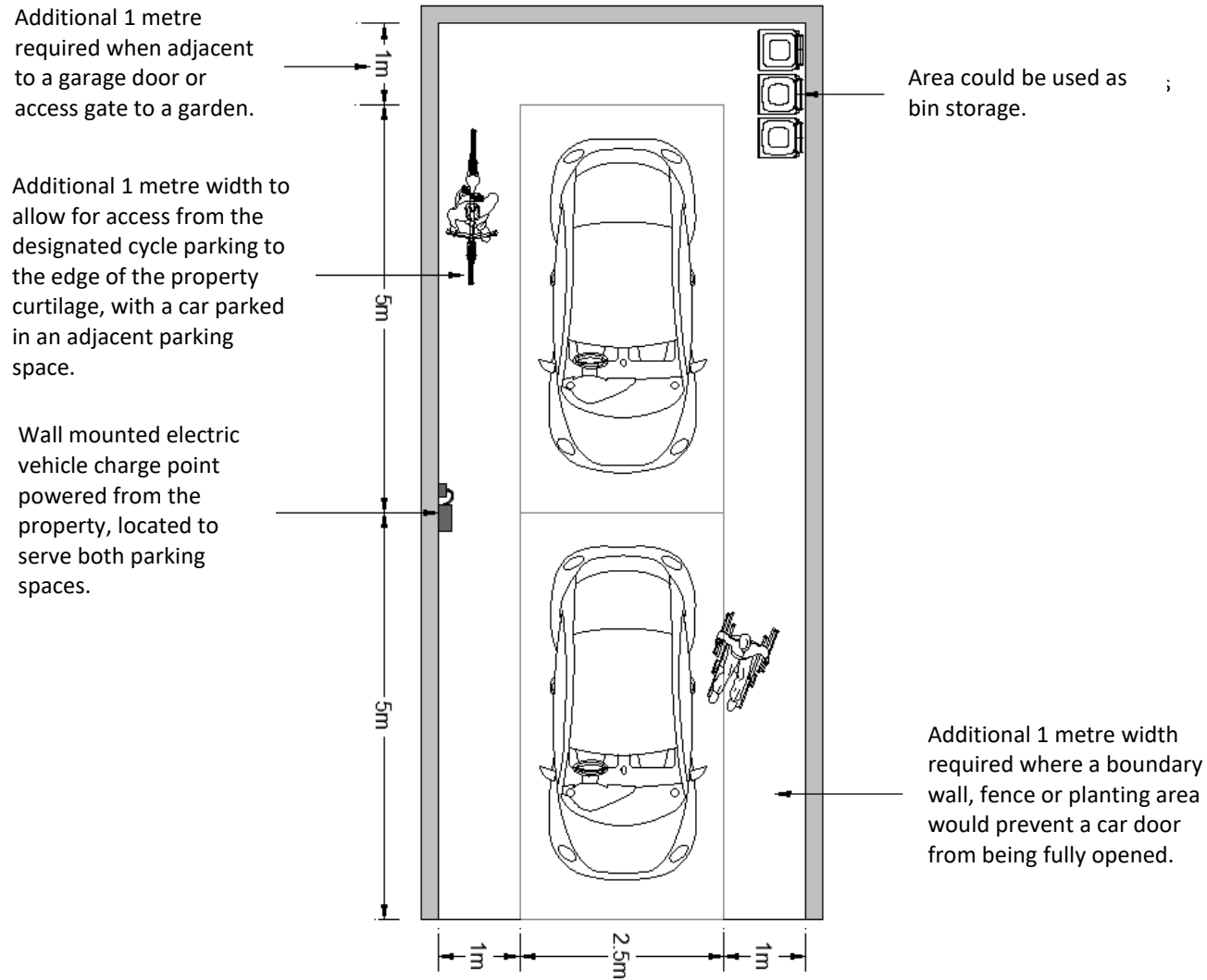

Note a maximum of 2 parking spaces can be arranged in a tandem arrangement.

## Appendix 21: Residential parking layouts – driveway for two vehicles in a tandem arrangement, with two driveways adjacent to one another

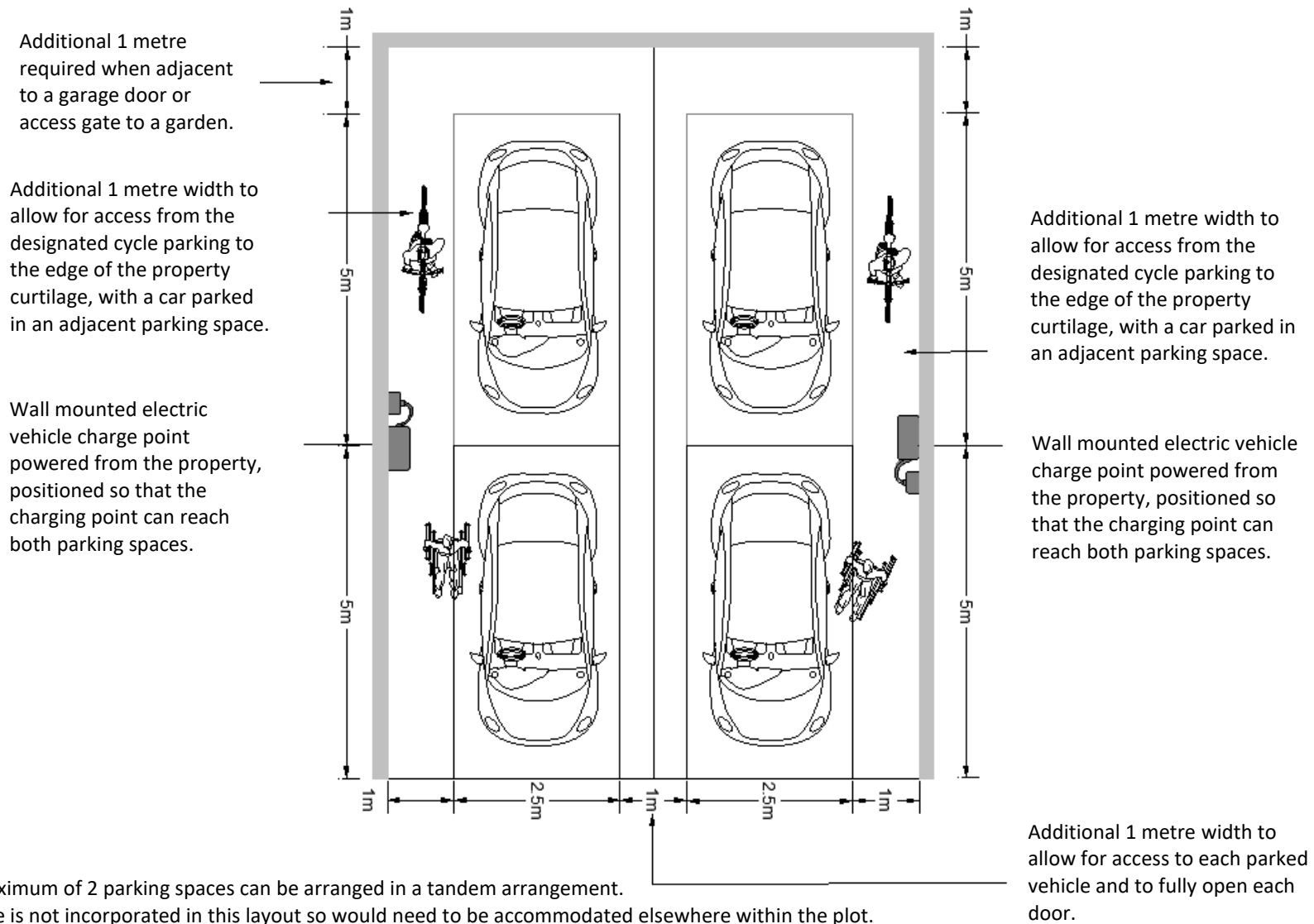

## Appendix 22: Residential parking layouts – driveway for three vehicles

Wall mounted electric vehicle charge point powered from the property.

Cycle lockers with space allowed for doors to be fully opened.

Low level planting with a maximum height of 0.6 metres within the visibility splay.

Dropped kerb to extend across both parking spaces and the cycle access to the cycle parking.

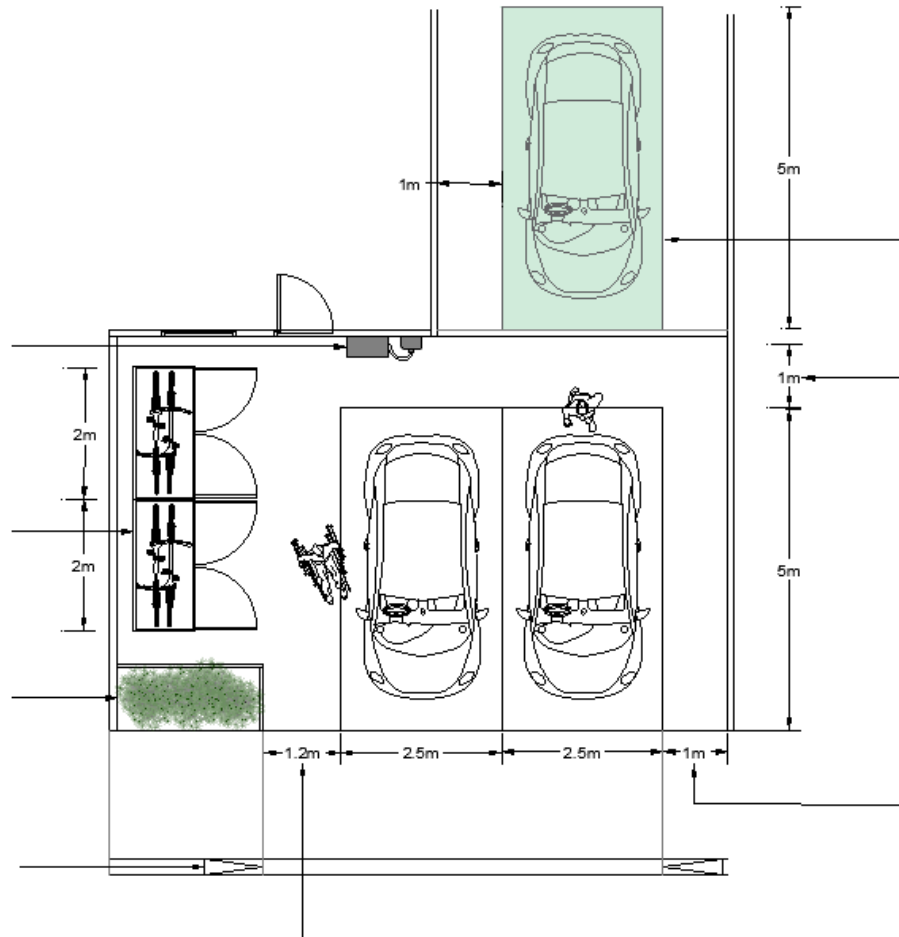

Space for a third parking space could be provided in the garden as green space, enabling the resident to surface the space if required.

Space behind parking spaces can be reduced to 1 metre when the spaces are not directly overlooked by a window and cycle access has been accommodated elsewhere.

Additional 1 metre width required when adjacent to a solid structure such as a boundary wall or fence.

1.2-metre-wide pedestrian and cycle access to the front door and cycle lockers.

## Appendix 23: Residential parking layouts – driveway for three vehicles

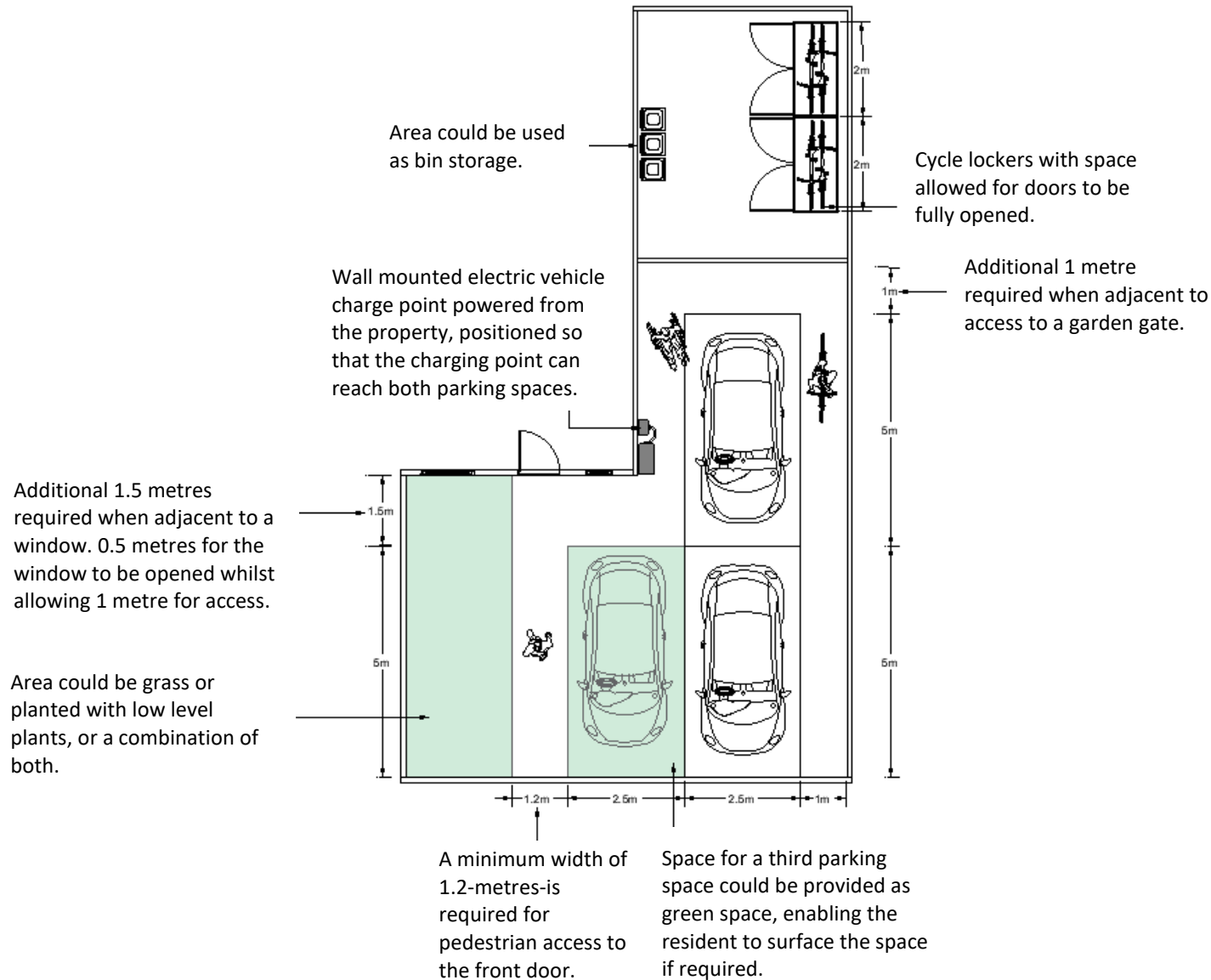

## Appendix 24: Residential parking layouts – driveway for four vehicles

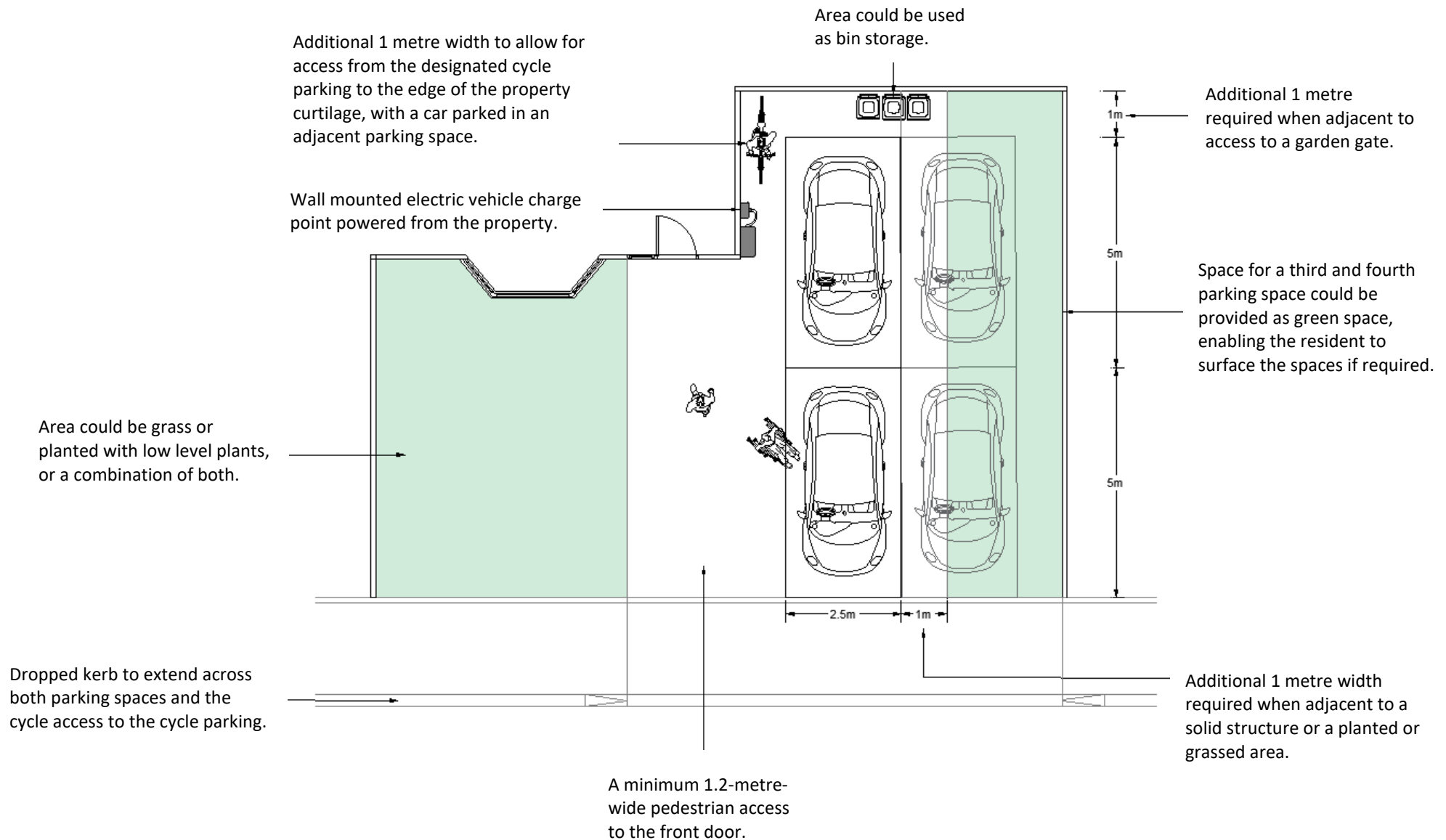

## Appendix 25: Residential parking layouts – driveway for four vehicles

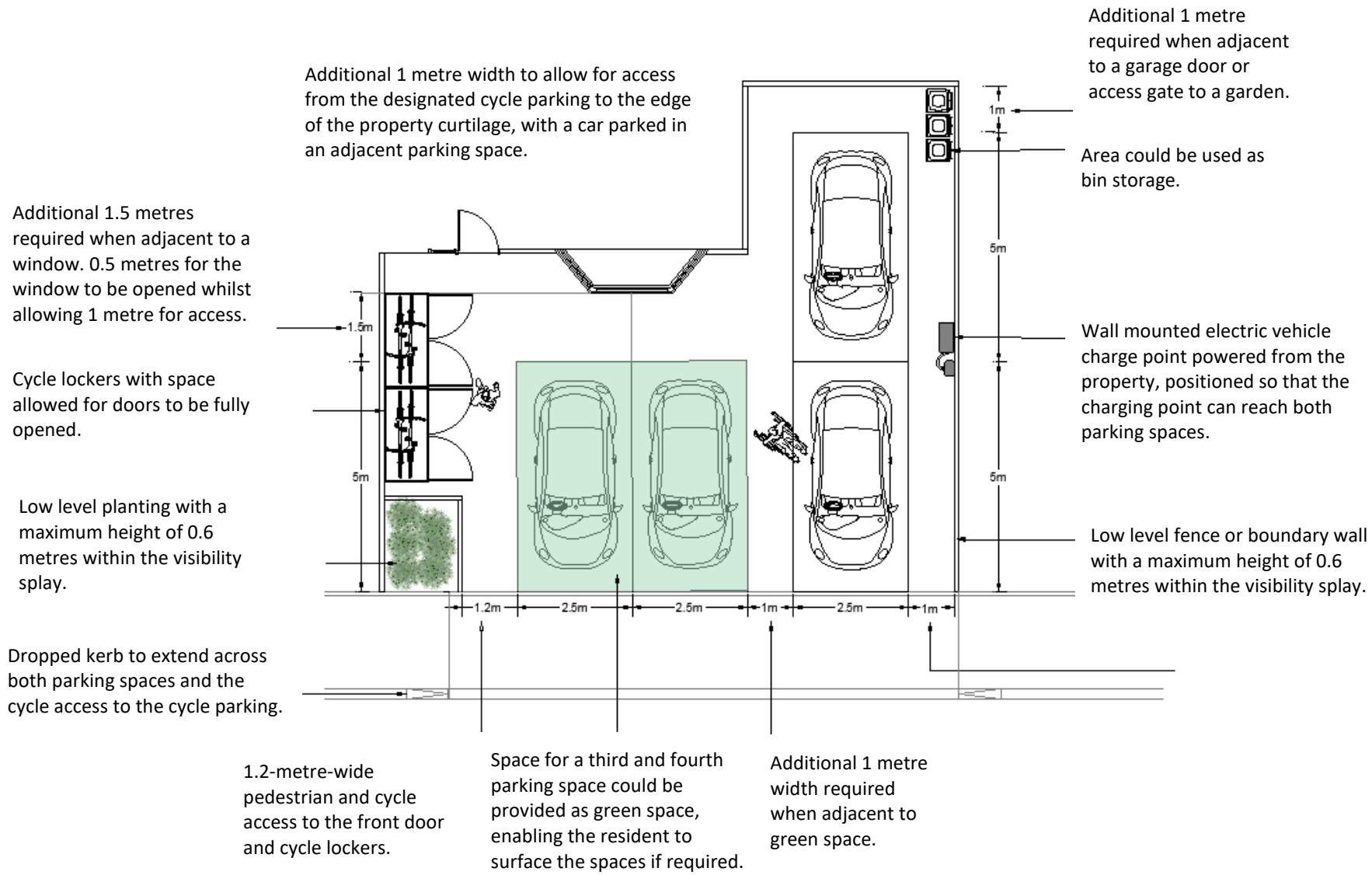

Note a maximum of 2 parking spaces can be arranged in a tandem arrangement.



## Appendix 26: Residential parking layouts – communal perpendicular parking with footway

Where possible, where more than one parking space is required for the same property, these should be located adjacent to one another.

Free standing electric vehicle charge point incorporating two charge point sockets. Controlled access required when allocated parking is in place.

Where a footway is to be provided it should be 2-metres wide behind the electric vehicle charge points. The area taken up by EV charge points could be demarcated.

Electric vehicle charge points that are ground fixed should have a measure in place to prevent a vehicle inadvertently driving into the charge point. This could include bollards, a guard provided by the manufacturer, or the charge point could be mounted on a kerbed footway.

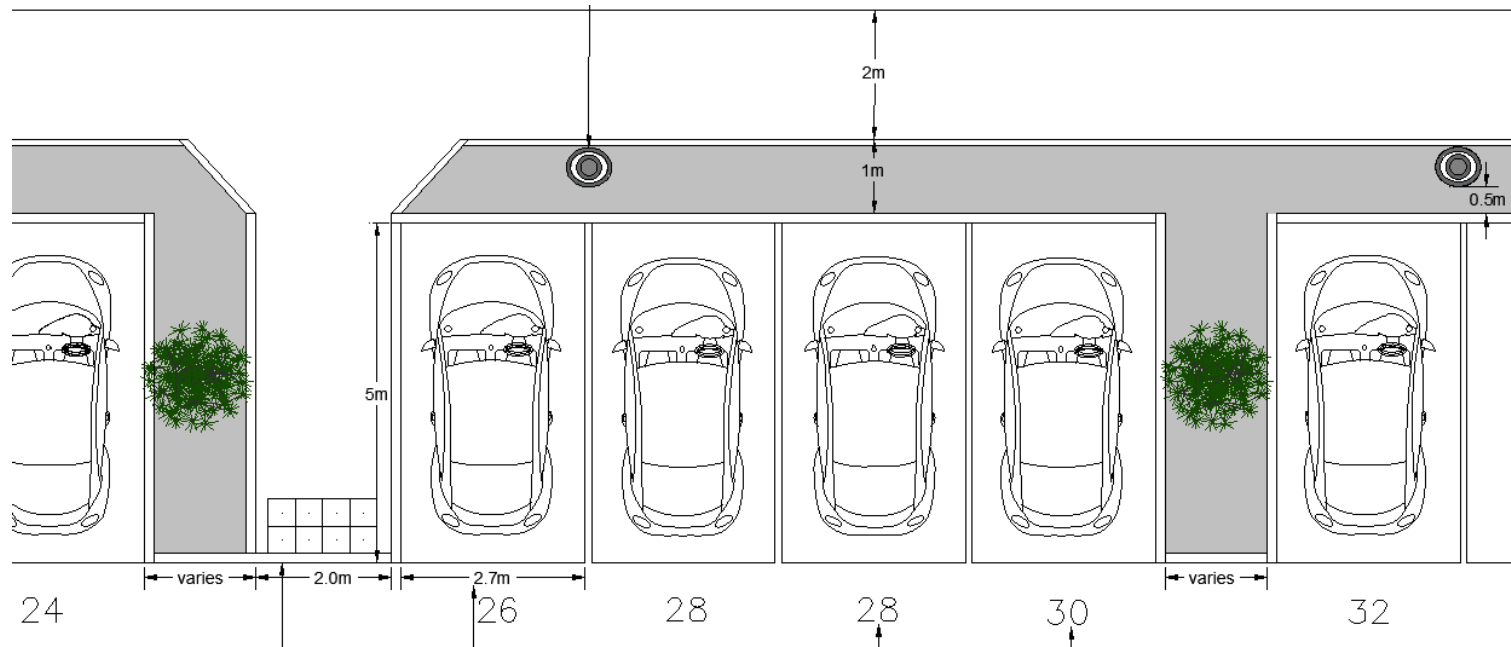

When mounted on a kerbed footway or island, an EV charge point should be set back a minimum of 0.5 metres.

A 2-metre-wide footway should be provided between a row of parking spaces at regular intervals.

Parking bays in communal layouts should have a minimum width of 2.7 metres. This will enable the resident to be able to wash their vehicle when parked or carry out basic vehicle maintenance.

Bays with passive EV provision.

A tree should be provided after every 4 parking spaces. The width required will depend on the tree species. Additional width should be provided for tree growth.

Parking bays in communal layouts should be allocated to properties and demarcated.

## Appendix 27: Residential parking layouts – communal perpendicular parking with pedestrian walkway

Free standing electric vehicle charge point incorporating two charge point sockets. Controlled access required when allocated parking is in place.

Where pedestrian access and access to cycle storage is provided between two dwellings, a minimum width of 2 metres is required.

Parking bays in communal layouts should be allocated to properties.

Electric vehicle charge points that are ground fixed should have a measure in place to prevent a vehicle inadvertently driving into the charge point. This could include bollards, a guard provided by the manufacturer, or the charge point could be mounted on a kerbed footway.

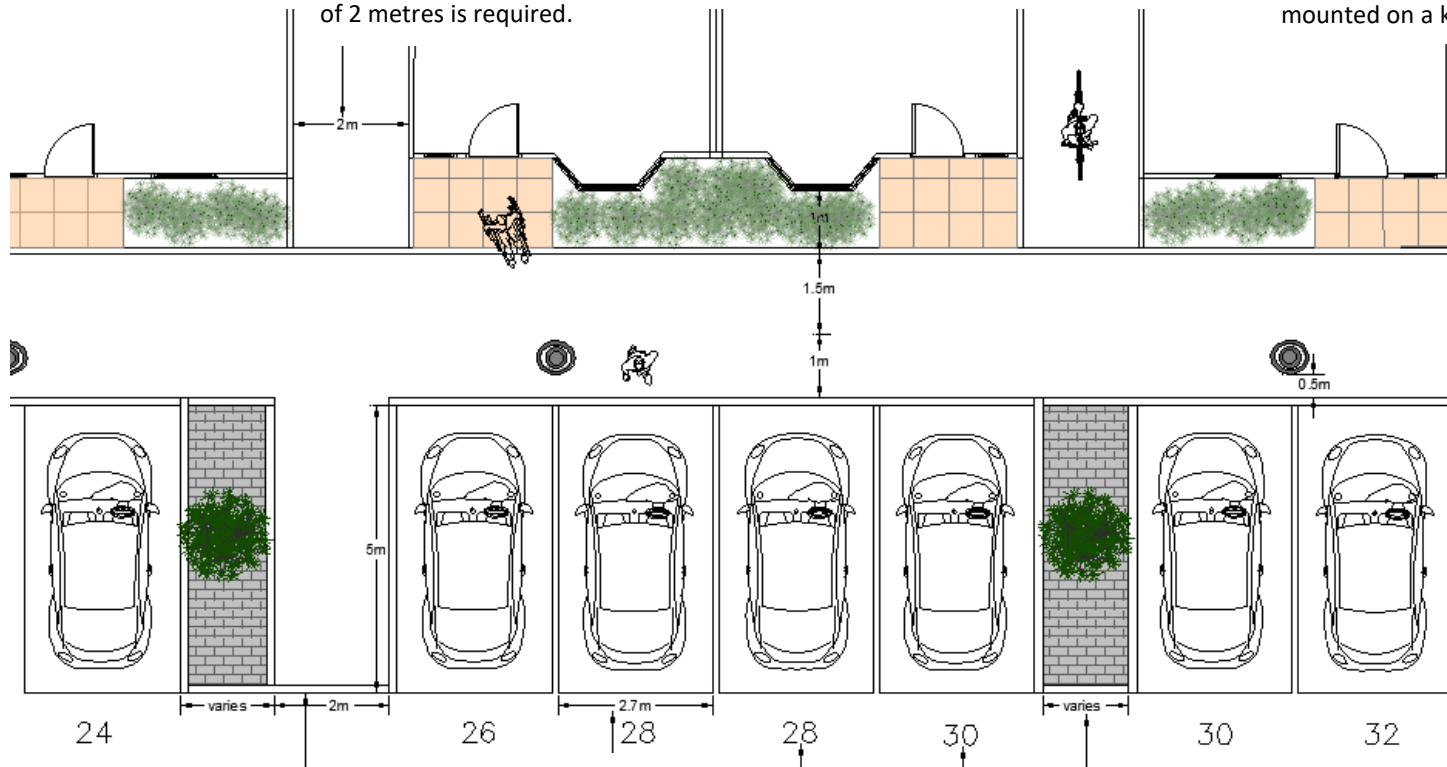

Where possible, where more than one parking space is required for the same property, these should be located adjacent to one another.

A 2-metre-wide footway should be provided between a row of parking spaces at regular intervals.

Parking bays in communal layouts should have a minimum width of 2.7 metres. This will enable the resident to be able to wash their vehicle when parked or carry out basic vehicle maintenance.

Bays with passive EV provision.

A tree should be provided after every 4 parking spaces. The width required will depend on the tree species. Additional width should be provided for tree growth.

## Appendix 28: Residential parking layouts – disabled parking

To be used for allocated spaces at communal flats and apartments relating to ground floor accommodation. These parking bays should be located as close to the property entrance as practicable. These dimensions should also be used for visitor spaces in communal developments.

A flush dropped kerb should be provided, to enable the disabled person to access the electric vehicle charge point and the footway behind (where provided).

When mounted on a kerbed footway or island, an EV charge point should be set back a minimum of 0.5 metres.

Where a footway is to be provided it should be 2-metres wide behind the electric vehicle charge points. The area taken up by EV charge points could be demarcated.

Free standing electric vehicle charge point incorporating two charge point sockets. Controlled access required when allocated parking is in place.

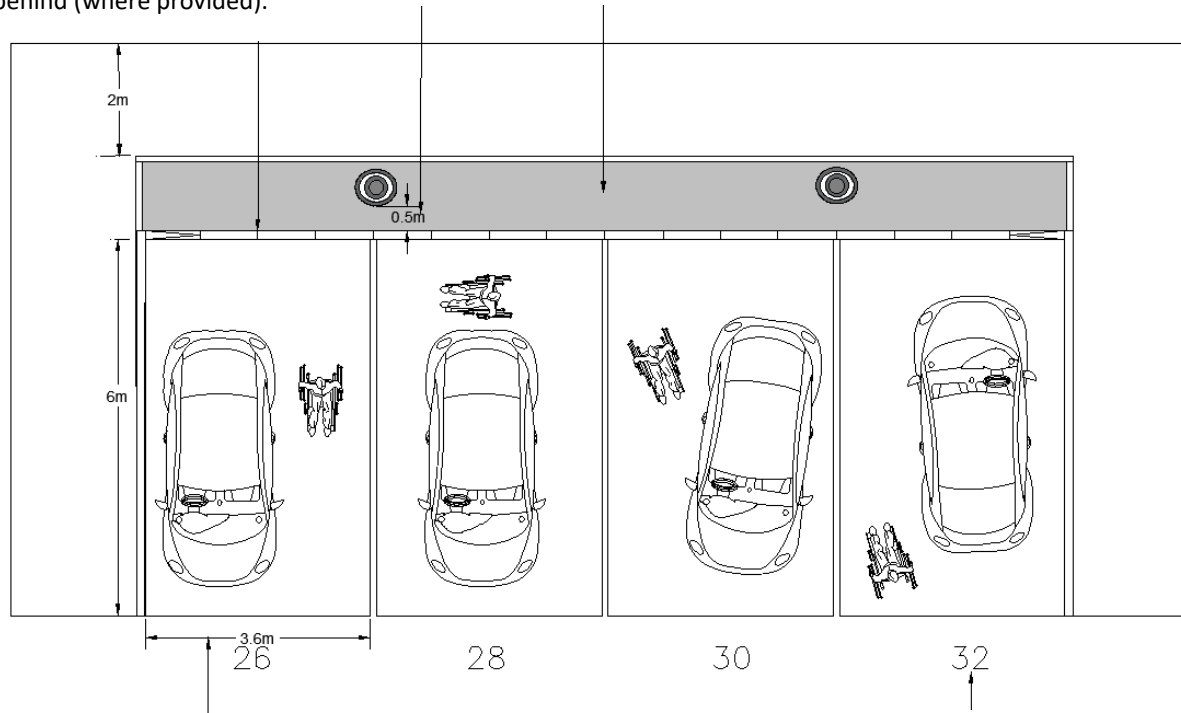

EV charge points to be located between each parking bay, so that the dropped kerb is not blocked, and wheelchair access is maintained.

Parking bays in communal layouts that could be used by a disabled person should be 3.6 metres wide and 6 metres long.

Parking bays in communal layouts should be allocated to properties, and therefore don't need to be marked as 'disabled'.

## Appendix 29: Residential parking layouts – on-street parallel lay-by parking

Proposed lay-by for visitor parking. Note the larger dimensions to allow use by disabled blue badge holders and delivery vehicles.

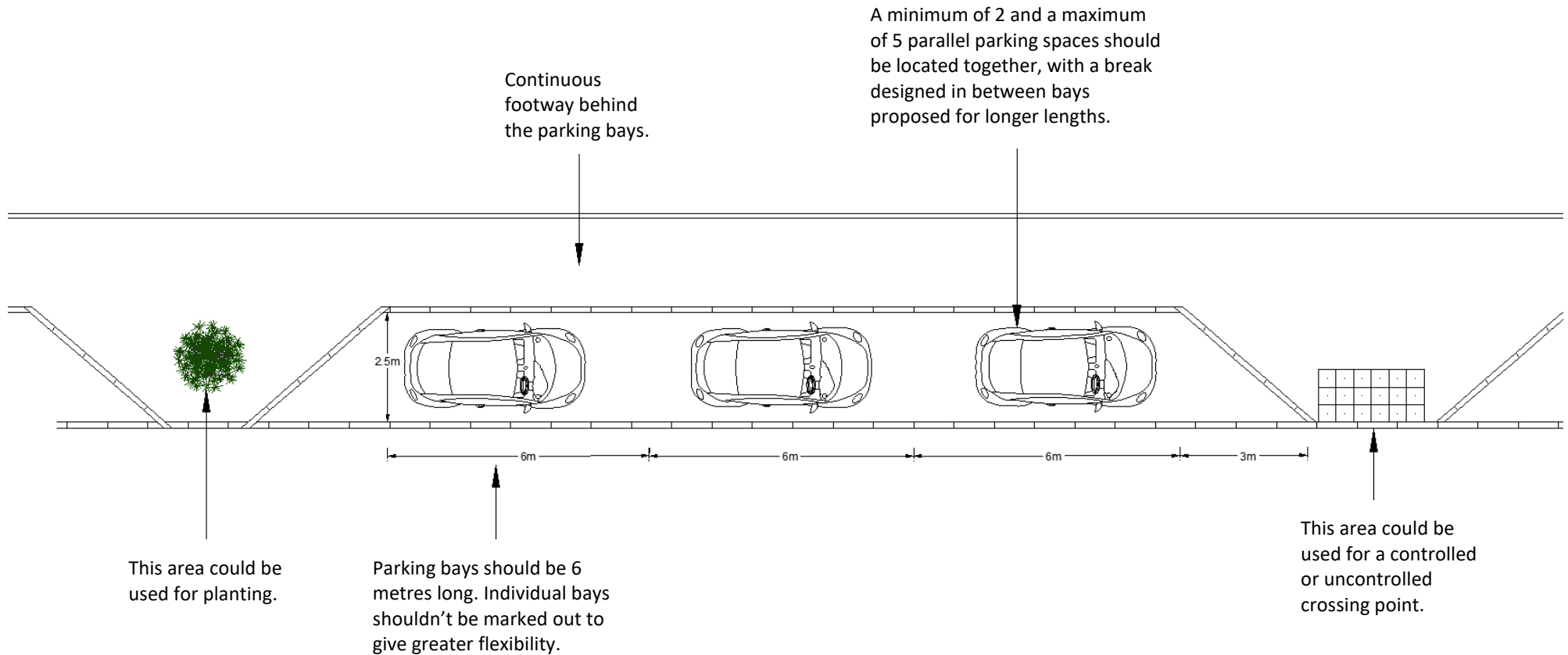

## Appendix 30: Non-residential parking layouts: Perpendicular parking

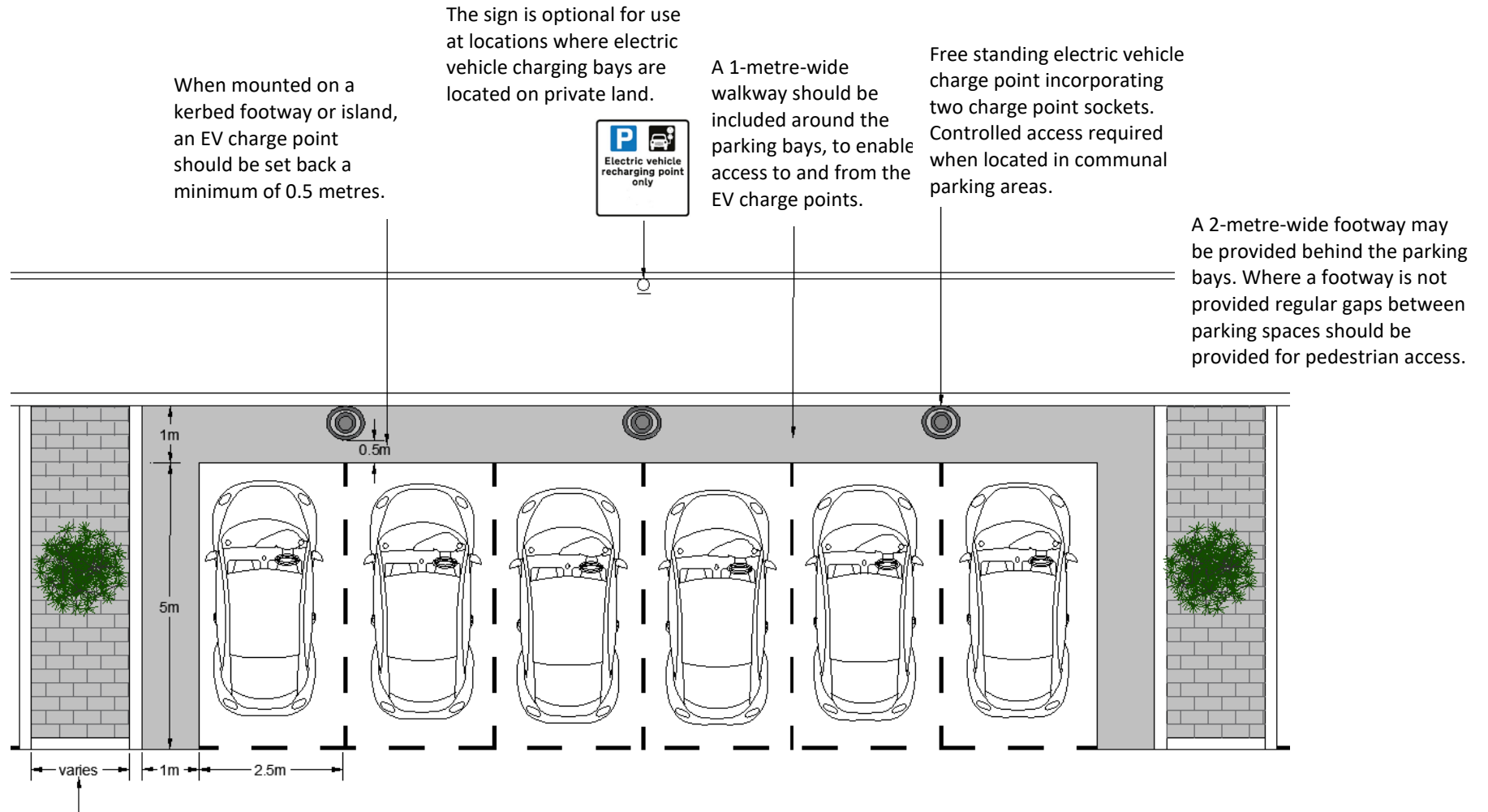

When mounted on a kerbed footway or island, an EV charge point should be set back a minimum of 0.5 metres.

The sign is optional for use at locations where electric vehicle charging bays are located on private land.



A 1-metre-wide walkway should be included around the parking bays, to enable access to and from the EV charge points.

Free standing electric vehicle charge point incorporating two charge point sockets. Controlled access required when located in communal parking areas.

A 2-metre-wide footway may be provided behind the parking bays. Where a footway is not provided regular gaps between parking spaces should be provided for pedestrian access.

A tree should be provided after every 6 parking spaces. The width required will depend on the tree species. Additional width should be provided for tree growth.

## Appendix 31: Non-residential parking layouts: perpendicular parking incorporating disabled parking, cycle parking and powered two-wheeler parking

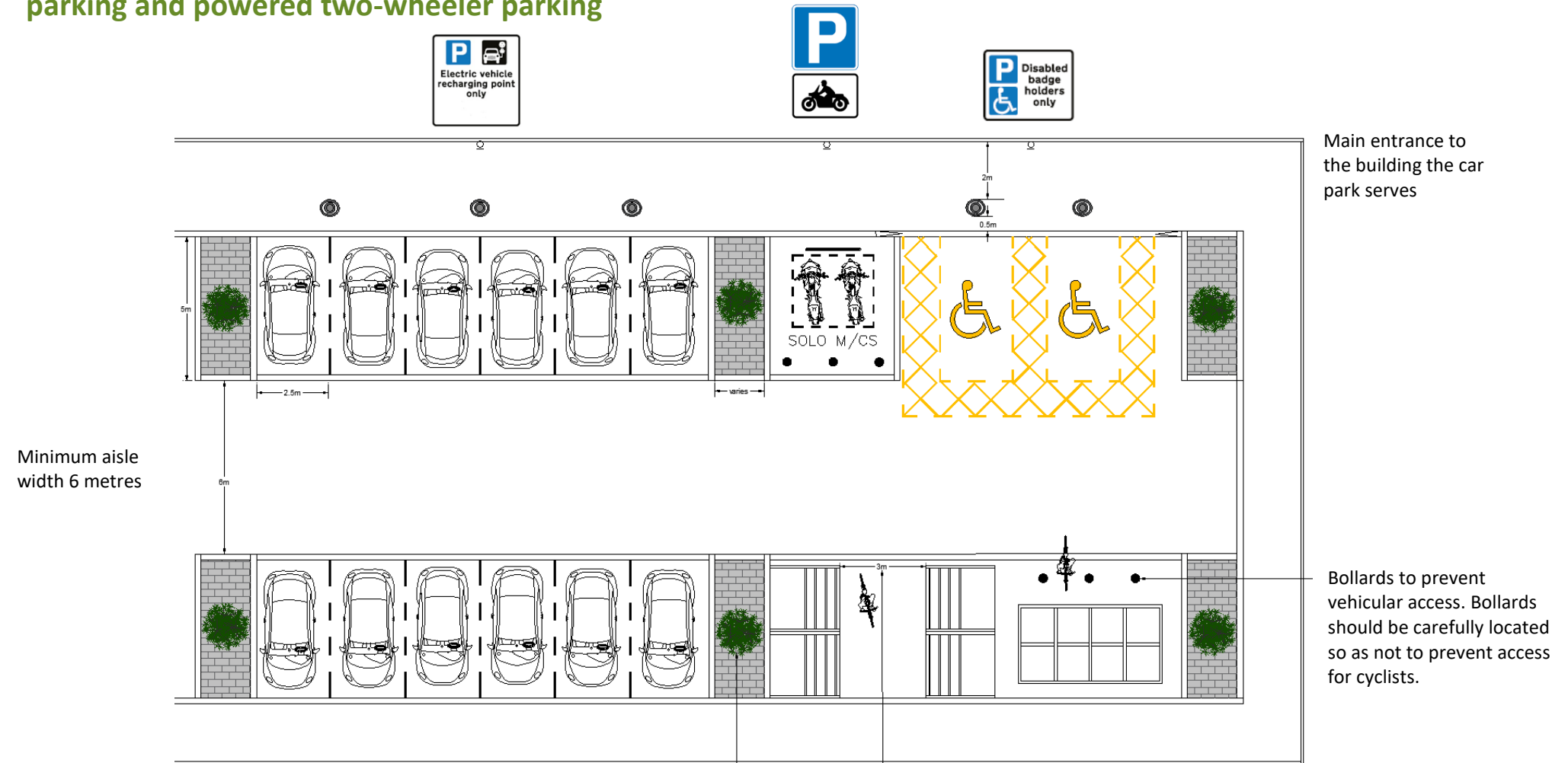

The signs and road markings shown are optional when a car park is on private land, however bays for specific uses must be clearly identifiable.

A tree should be provided after every 6 parking spaces. The width required will depend on the tree species. Additional width should be provided for tree growth.

4 x 'street shelter' lockable cycle shelters for longer term cycle parking. Aisle width should be a minimum of 3 metres.

Sheffield cycle stands underneath a shelter for visitor parking.



## Appendix 32: Disabled parking at off-street locations

To be used for off-street car parks and recommended for disabled parking bays on private land.

Where a footway is provided behind disabled parking bays, the footway should have a remaining clear width of 2 metres once the electric vehicle charge points are in situ.

A 'Disabled badge holders only' sign is desirable and should be carefully located so as not to block access from the disabled parking bays to the footway (where provided) or EV charge point.

Electric vehicle charge points should be located so that they don't block access from the hatched areas in between bays. It may not be possible for two adjacent disabled parking bays to share an EV charge point to avoid cables trailing over walkways.

When mounted on a kerbed footway or island, an EV charge point should be set back a minimum of 0.5 metres.

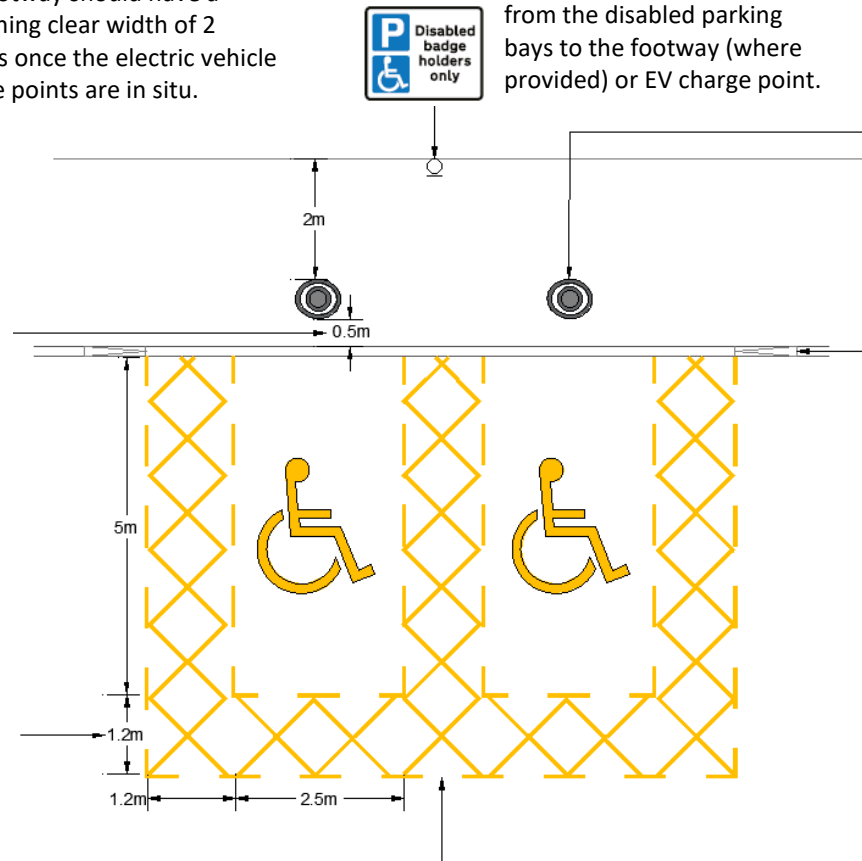

A dropped kerb or flush surface between the parking bay and any adjacent footway must be provided, to ensure a disabled person can access the electric vehicle charge point.

A 1.2-metre-wide hatched area should be provided around each disabled parking space. The 1.2-metre-wide area at the end of the bay is desirable (and will be required for new developments) but may be relaxed where parking spaces need to be retrofitted into existing car parks or areas with constrained space.

If more than one disabled parking space are provided adjacent to one another, the 1.2-metre-wide hatched area can be shared by both parking bays.

## Appendix 33: Disabled parking at on-street locations

To be used for on-street parking where the road is public highway or is intended to be offered up for adoption.

A 'Disabled badge holders only' sign is required and should be carefully located so as not to block access from the disabled parking bays to the footway (where provided) or EV charge point. A Traffic Regulation Order is also required.



Where a footway is to be provided it should be 2-metres wide behind the electric vehicle charge points. The area taken up by EV charge points could be demarcated.

A dropped kerb or flush surface between the parking bay and any adjacent footway must be provided, to ensure a disabled person can access the electric vehicle charge point.

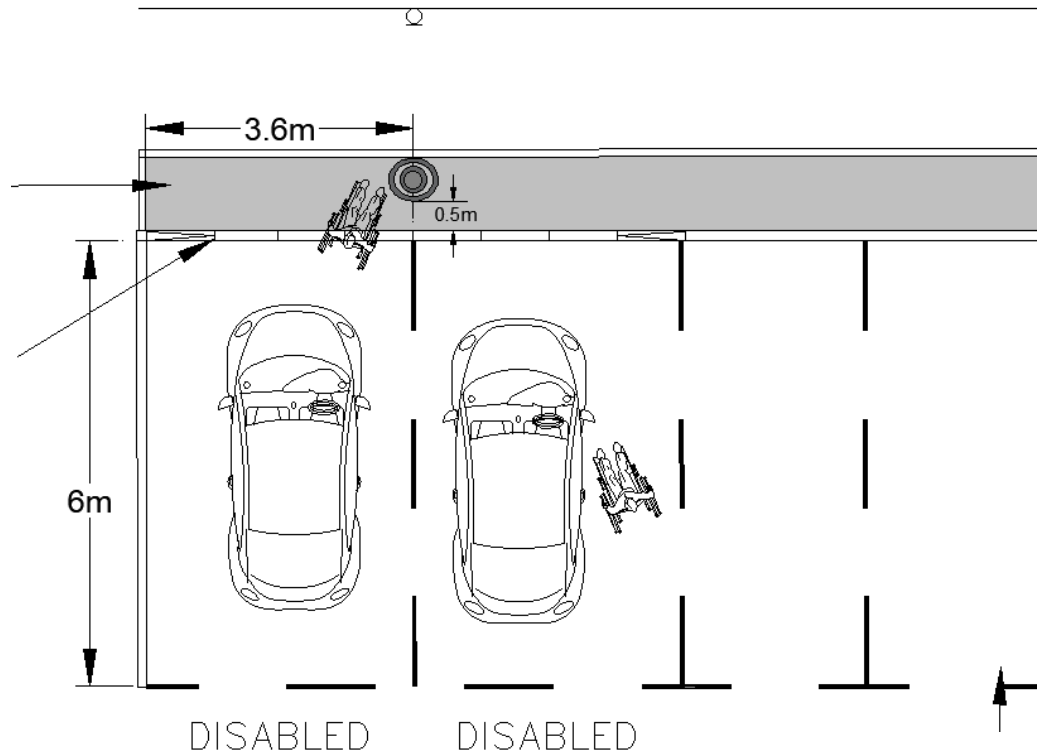

When mounted on a kerbed footway or island, an EV charge point should be set back a minimum of 0.5 metres.

When standard parking bays are located adjacent to disabled bays, the length of these bays should be increased to 6 metres instead of the standard 5 metres to avoid an awkward step.

## Appendix 34: Car Club parking bays, parallel parking

The sign is optional for use at locations where car club bays are located on private land. A Traffic Regulation Order must be in place when this sign is used in car club parking bays on the public highway or on land that will be offered up for adoption.

A 1-metre-wide walkway should be included around the parking bays, to enable access to and from the EV charge points.



Free standing electric vehicle charge point incorporating two charge point sockets. Controlled access required when located in communal parking areas.

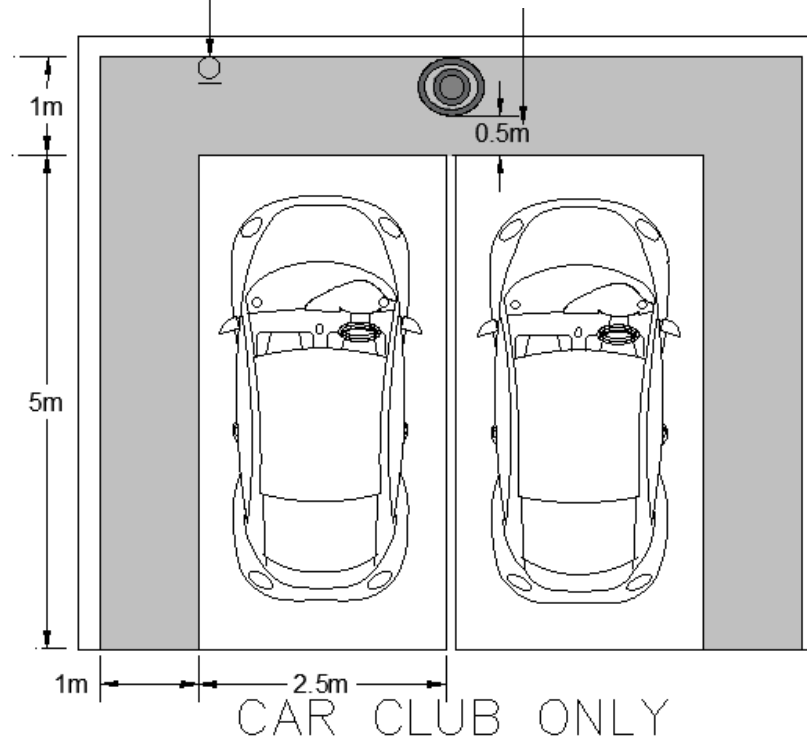

Electric vehicle charge points that are ground fixed should have a measure in place to prevent a vehicle inadvertently driving into the charge point. This could include bollards, a guard provided by the manufacturer, or the charge point could be mounted on a kerbed footway.

## Appendix 35: Car Club parking bays in a lay-by arrangement

The sign is optional for use at locations where car club bays are located on private land. A Traffic Regulation Order must be in place when this sign is used in car club parking bays on the public highway or on land that will be offered up for adoption.

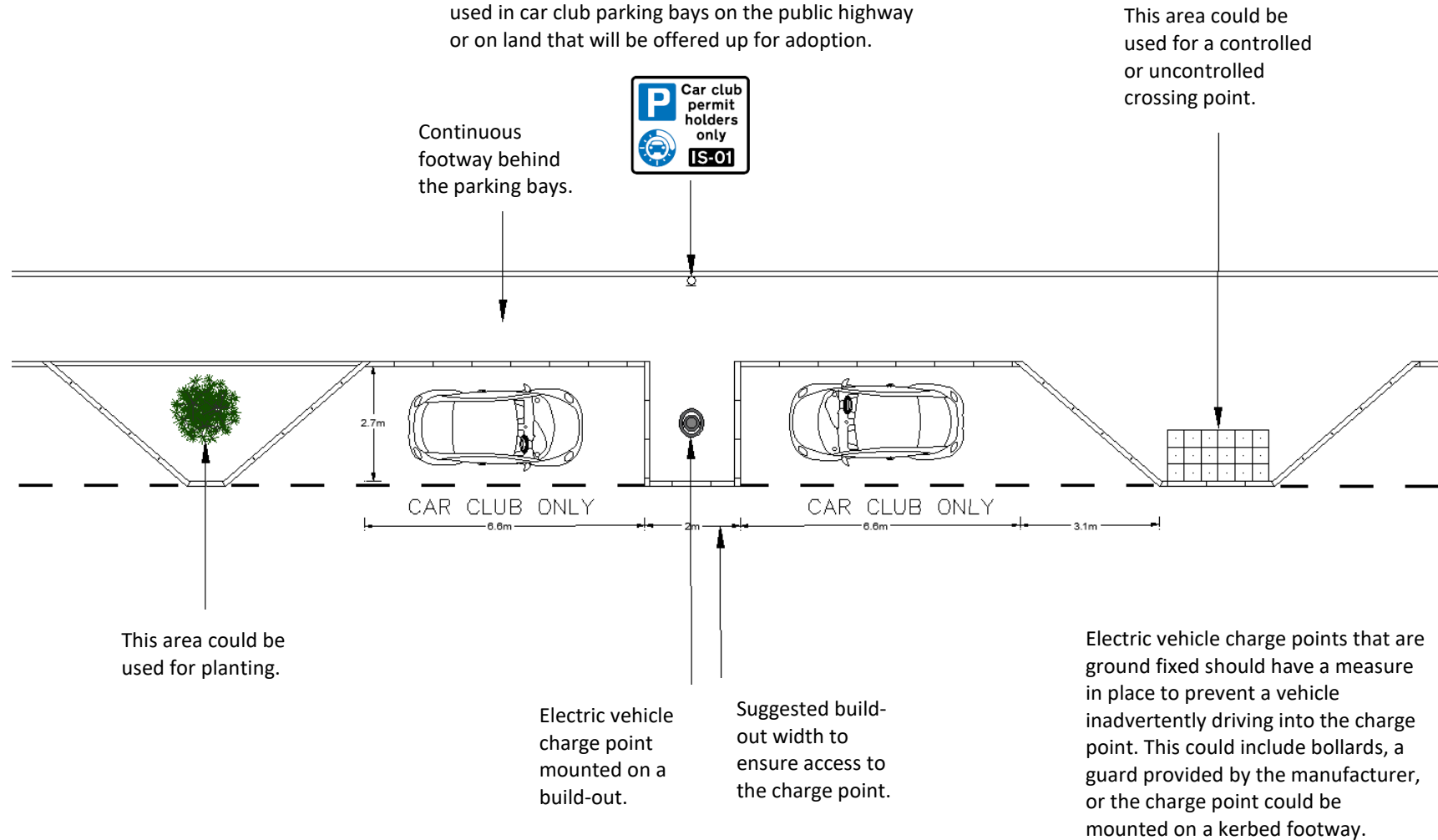

## Appendix 36: Powered two-wheeler parking

To be used for both on-street and off-street powered two-wheeler parking. Dimensions can be used for provision at residential settings.

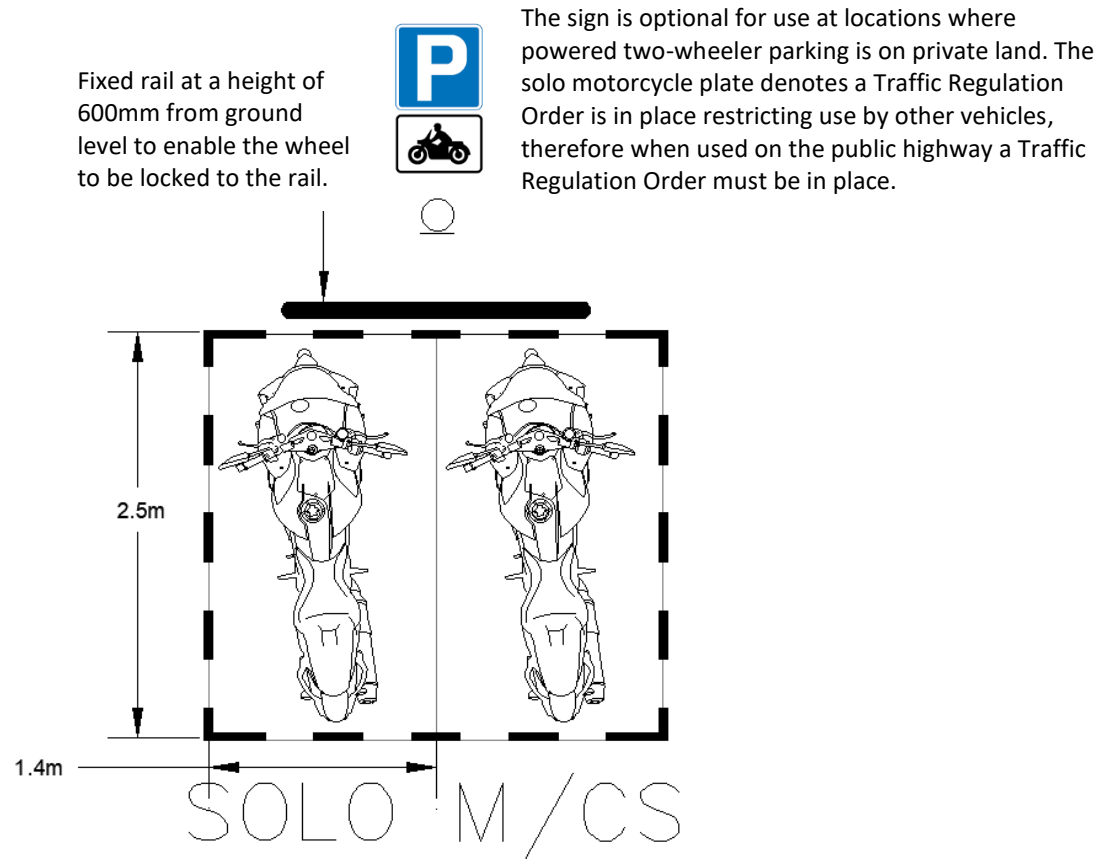

# **Central Bedfordshire in contact**

**Find us online:** [www.centralbedfordshire.gov.uk](http://www.centralbedfordshire.gov.uk)

**Email:** [strategic.transport@centralbedfordshire.gov.uk](mailto:strategic.transport@centralbedfordshire.gov.uk)

**Write to:** Central Bedfordshire Council, Priory House,  
Monks Walk, Chicksands, Shefford, Bedfordshire SG17 5TQ